

# PARTS MANUAL



***WHITEMAN* SERIES**  
**MODEL HHN-34TVD**  
**RIDE-ON POWER TROWEL**  
**(B & S VANGUARD DIESEL ENGINE)**

Revision #9 (04/26/11)

To find the latest revision of this  
publication, visit our website at:  
[www.multiquip.com](http://www.multiquip.com)



**THIS MANUAL MUST ACCOMPANY THE EQUIPMENT AT ALL TIMES.**

**P/N 21730**



**CALIFORNIA — Proposition 65 Warning**

Engine exhaust and some of its constituents, and some dust created by power sanding, sawing, grinding, drilling and other construction activities contains chemicals known to the State of California to cause cancer, birth defects and other reproductive harm. Some examples of these chemicals are:

- Lead from lead-based paints.
- Crystalline silica from bricks.
- Cement and other masonry products.
- Arsenic and chromium from chemically treated lumber.

Your risk from these exposures varies, depending on how often you do this type of work. To reduce your exposure to these chemicals: **ALWAYS** work in a well ventilated area, and work with approved safety equipment, such as dust masks that are specially designed to filter out microscopic particles.

## **WARNING**

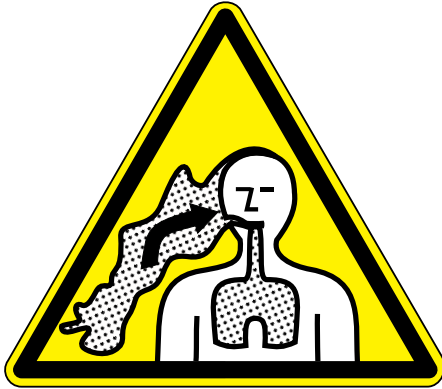

### **SILICOSIS WARNING**

Grinding/cutting/drilling of masonry, concrete, metal and other materials with silica in their composition may give off dust or mists containing crystalline silica. Silica is a basic component of sand, quartz, brick clay, granite and numerous other minerals and rocks. Repeated and/or substantial inhalation of airborne crystalline silica can cause serious or fatal respiratory diseases, including silicosis. In addition, California and some other authorities have listed respirable crystalline silica as a substance known to cause cancer. When cutting such materials, always follow the respiratory precautions mentioned above.

## **WARNING**

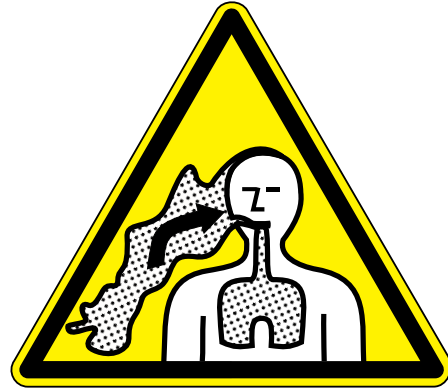

### **RESPIRATORY HAZARDS**

Grinding/cutting/drilling of masonry, concrete, metal and other materials can generate dust, mists and fumes containing chemicals known to cause serious or fatal injury or illness, such as respiratory disease, cancer, birth defects or other reproductive harm. If you are unfamiliar with the risks associated with the particular process and/or material being cut or the composition of the tool being used, review the material safety data sheet and/or consult your employer, the material manufacturer/supplier, governmental agencies such as OSHA and NIOSH and other sources on hazardous materials. California and some other authorities, for instance, have published lists of substances known to cause cancer, reproductive toxicity, or other harmful effects.

Control dust, mist and fumes at the source where possible. In this regard use good work practices and follow the recommendations of the manufacturers or suppliers, OSHA/NIOSH, and occupational and trade associations. Water should be used for dust suppression when wet cutting is feasible. When the hazards from inhalation of dust, mists and fumes cannot be eliminated, the operator and any bystanders should always wear a respirator approved by NIOSH/MSHA for the materials being used.

## MQ WHITEMAN — HHN-34TVD DIESEL POWERED RIDE-ON TROWEL

Proposition 65 Warning .....	2
Silicosis/Respiratory Warnings .....	3
Table Of Contents .....	4
Parts Ordering Procedures.....	5
Explanation Of Codes In Remarks Column.....	6
Suggested Spare Parts .....	7
Nameplate And Decals.....	8-9
Steering Control Handles Assembly.....	10-11
Steering Control (Assist) Assembly .....	12-13
Gear Box/Pivot Assembly .....	14-15
Gear Box Assembly .....	16-17
Twin Pitch Handle Assembly (Left & Right) .....	18-19
Twin Pitch Tower Assembly (Left & Right).....	20-21
Twin Pitch Miter Assembly (Left & Right).....	22-23
Engine and Mounts Assembly.....	24-25
Engine - Air Cleaner & Throttle.....	26-27
Engine Radiator Assembly .....	28-29
Engine Muffler Assembly .....	30-31
Engine Clutch Assembly (Old Style).....	32-33
Engine Clutch Assembly (New Style) .....	34-35
Fuel Assembly .....	36-37
Drive Assembly (Old Style).....	38-39
Drive Assembly (New Style) .....	40-41
5-Blade Spider Assembly (Left).....	42-43
5-Blade Spider Assembly (Right) .....	44-45
Stabilizer Ring Assembly .....	46-47
Seat and Frame Assembly .....	48-49
Frame and Components Assembly .....	50-51
Foot Pedals Assembly .....	52-53
Battery Assembly.....	54-55
Spray Assembly.....	56-57
Lights Assembly .....	58-59
Front Panel Assembly.....	60-61
Top Right Panel Assembly .....	62-63
E-Z Mover and Lift Assembly.....	64-65
Terms and Conditions Of Sale.....	66

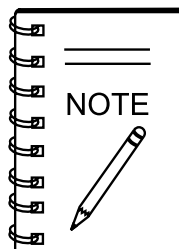

***Specifications and part numbers are subject to change without notice.***

# PARTS ORDERING PROCEDURES

## Ordering parts has never been easier! Choose from three easy options:

Effective:  
January 1<sup>st</sup>, 2006

www.multiquip.com



### Order via Internet (Dealers Only):

Order parts on-line using Multiquip's SmartEquip website!

- View Parts Diagrams
- Order Parts
- Print Specification Information



If you have an MQ Account, to obtain a Username and Password, E-mail us at: [parts@multiquip.com](mailto:parts@multiquip.com).

To obtain an MQ Account, contact your District Sales Manager for more information.

Goto [www.multiquip.com](http://www.multiquip.com) and click on **Order Parts** to log in and save!

Use the **internet** and qualify for a **5% Discount** on *Standard orders* for all orders which include complete part numbers.\*

Note: Discounts Are Subject To Change



### Order via Fax (Dealers Only):

All customers are welcome to order parts via Fax.

**Domestic (US) Customers dial:**  
1-800-6-PARTS-7 (800-672-7877)

**Fax** your order in and qualify for a **2% Discount** on *Standard orders* for all orders which include complete part numbers.\*

Note: Discounts Are Subject To Change



**Order via Phone: Domestic (US) Dealers Call:**  
1-800-427-1244

### Non-Dealer Customers:

Contact your local Multiquip Dealer for parts or call 800-427-1244 for help in locating a dealer near you.



**International Customers** should contact their local Multiquip Representatives for Parts Ordering information.

## When ordering parts, please supply:

- |   |  |
|---|--|
| <input type="checkbox"/> Dealer Account Number                                | <input type="checkbox"/> Specify Preferred Method of Shipment:                         |
| <input type="checkbox"/> Dealer Name and Address                              | <input checked="" type="checkbox"/> UPS/Fed Ex <input checked="" type="checkbox"/> DHL |
| <input type="checkbox"/> Shipping Address (if different than billing address) | <input type="checkbox"/> Priority One <input checked="" type="checkbox"/> Truck        |
| <input type="checkbox"/> Return Fax Number                                    | <input type="checkbox"/> Ground  |
| <input type="checkbox"/> Applicable Model Number                              | <input type="checkbox"/> Next Day  |
| <input type="checkbox"/> Quantity, Part Number and Description of Each Part   | <input type="checkbox"/> Second/Third Day  |

### NOTICE

All orders are treated as *Standard Orders* and will ship the same day if received prior to 3PM PST.

WE ACCEPT ALL MAJOR CREDIT CARDS!



# EXPLANATION OF CODE IN REMARKS COLUMN

The following section explains the different symbols and remarks used in the Parts section of this manual. Use the help numbers found on the back page of the manual if there are any questions.

## NOTICE

The contents and part numbers listed in the parts section are subject to change **without notice**. Multiquip does not guarantee the availability of the parts listed.

## SAMPLE PARTS LIST

NO.	PART NO.	PART NAME	QTY.	REMARKS
1	12345	BOLT.....	1	INCLUDES ITEMS W/%
2%		WASHER, 1/4 IN.....		NOT SOLD SEPARATELY
2%	12347	WASHER, 3/8 IN....	1	MQ-45T ONLY
3	12348	HOSE .....	A/R	MAKE LOCALLY
4	12349	BEARING .....	1	S/N 2345B AND ABOVE

## NO. Column

**Unique Symbols** — All items with same unique symbol

(@, #, +, %, or >) in the number column belong to the same assembly or kit, which is indicated by a note in the “Remarks” column.

**Duplicate Item Numbers** — Duplicate numbers indicate multiple part numbers, which are in effect for the same general item, such as different size saw blade guards in use or a part that has been updated on newer versions of the same machine.

## NOTICE

When ordering a part that has more than one item number listed, check the remarks column for help in determining the proper part to order.

## PART NO. Column

**Numbers Used** — Part numbers can be indicated by a number, a blank entry, or TBD.

TBD (To Be Determined) is generally used to show a part that has not been assigned a formal part number at the time of publication.

A blank entry generally indicates that the item is not sold separately or is not sold by Multiquip. Other entries will be clarified in the “Remarks” Column.

## QTY. Column

**Numbers Used** — Item quantity can be indicated by a number, a blank entry, or A/R.

A/R (As Required) is generally used for hoses or other parts that are sold in bulk and cut to length.

A blank entry generally indicates that the item is not sold separately. Other entries will be clarified in the “Remarks” Column.

## REMARKS Column

Some of the most common notes found in the “Remarks” Column are listed below. Other additional notes needed to describe the item can also be shown.

**Assembly/Kit** — All items on the parts list with the same unique symbol will be included when this item is purchased.

Indicated by:

“INCLUDES ITEMS W/(unique symbol)”

**Serial Number Break** — Used to list an effective serial number range where a particular part is used.

Indicated by:

“S/N XXXXX AND BELOW”

“S/N XXXX AND ABOVE”

“S/N XXXX TO S/N XXX”

**Specific Model Number Use** — Indicates that the part is used only with the specific model number or model number variant listed. It can also be used to show a part is NOT used on a specific model or model number variant.

Indicated by:

“XXXXX ONLY”

“NOT USED ON XXXX”

**“Make/Obtain Locally”** — Indicates that the part can be purchased at any hardware shop or made out of available items. Examples include battery cables, shims, and certain washers and nuts.

**“Not Sold Separately”** — Indicates that an item cannot be purchased as a separate item and is either part of an assembly/kit that can be purchased, or is not available for sale through Multiquip.

# HHN 34TVD — SUGGESTED SPARE PARTS

## HHN34TVD ENGINE

### 1 to 3 Units

Qty.	P/N	Description
4.....	2267.....	HANDLE GRIP
1.....	11430.....	SWITCH, SPRAY
2.....	12460.....	CABLE, PITCH
1.....	1617.....	LEVER ASSY. TROWEL ADJUSTMENT
2.....	2737.....	KNOB ASSY.
2.....	10434.....	CLAMP
1.....	2124.....	THROTTLE CABLE
5.....	2829.....	ARMS
2.....	11903.....	LEVER TROWEL ARM (L.S.)
20.....	0166 A.....	WASHER
20.....	1876.....	JAM NUT
5.....	11039.....	BUSHING
2.....	9111.....	SPRING (L.S.)
20.....	1875.....	WASHER
20.....	1322.....	SCREW ASSY., ARM RETAINING
2.....	12931.....	SPIDER PLATE
20.....	1162 A.....	CAP GREASE FITTING
20.....	11602.....	SCREW (SHS 3/8 -16 X .25)
20.....	1456.....	NUT (3/8 -16)
20.....	12097.....	SCREW (SQH 3/8-16 X 1 3/4 CONE)
2.....	2143.....	SPRING (R.S.)
2.....	11904.....	LEVER TROWEL ARM (R.S.)
2.....	12005.....	SAFETY STOP SWITCH (SAFETY ITEM)
2.....	11418.....	FUEL CAP/GAUGE
20.....	4514.....	SCREW (HHC 1/4-20 X 5/8)
1.....	825219.....	FUEL FILTER ASSEMBLY
2.....	820311.....	FUEL FILTER ELEMENT, 34TVD DIESEL
3.....	20138.....	BELT, CVT-VANGUARD COMET
3.....	23365.....	BELT, CVT-VANGUARD MULTI-CLUTCH
10.....	820263.....	AIR FILTER ELEMENT
10.....	820314.....	OIL FILTER ELEMENT
6.....	19473.....	CLAMP, WORM HOSE #4 (FUEL)

Qty.	P/N	Description
10.....	10031.....	WASHER 1/4 IN.
2.....	11692.....	BRACKET BATTERY
2.....	11693.....	BOLT BATTERY
6.....	2509.....	WING NUT
2.....	12548.....	SPRAY PUMP
2.....	2108.....	CAP SPRAY TANK
2.....	10958.....	SWITCH, IGNITION
1.....	19301.....	TERMINAL STRIP (10-POLE)
8.....	2918.....	CLAMP, HOSE
1.....	2673.....	CIRCUIT BREAKER 30 AMP, 12V
1.....	11098.....	CIRCUIT BREAKER 40 AMP, 12V
2.....	4682.....	TOGGLE SWITCH
2.....	8381.....	BOOT, TOGGLE SWITCH
1.....	11792.....	ACCESSORY SOLENOID
4.....	11078.....	KEYS, IGNITION (SWITCH)
5.....	12307.....	BULB, INDICATOR LIGHT
1.....	12018.....	RELAY, CONNECTOR (SAFETY ITEM)
1.....	12017.....	RELAY, KILL (SAFETY ITEM)

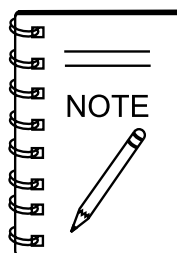

Part numbers on this Suggested Spare Parts List may supercede/replace the P/N shown in the text pages of this book.

# HHN 34TVD — NAME PLATE AND DECALS

## NAME PLATE AND DECALS

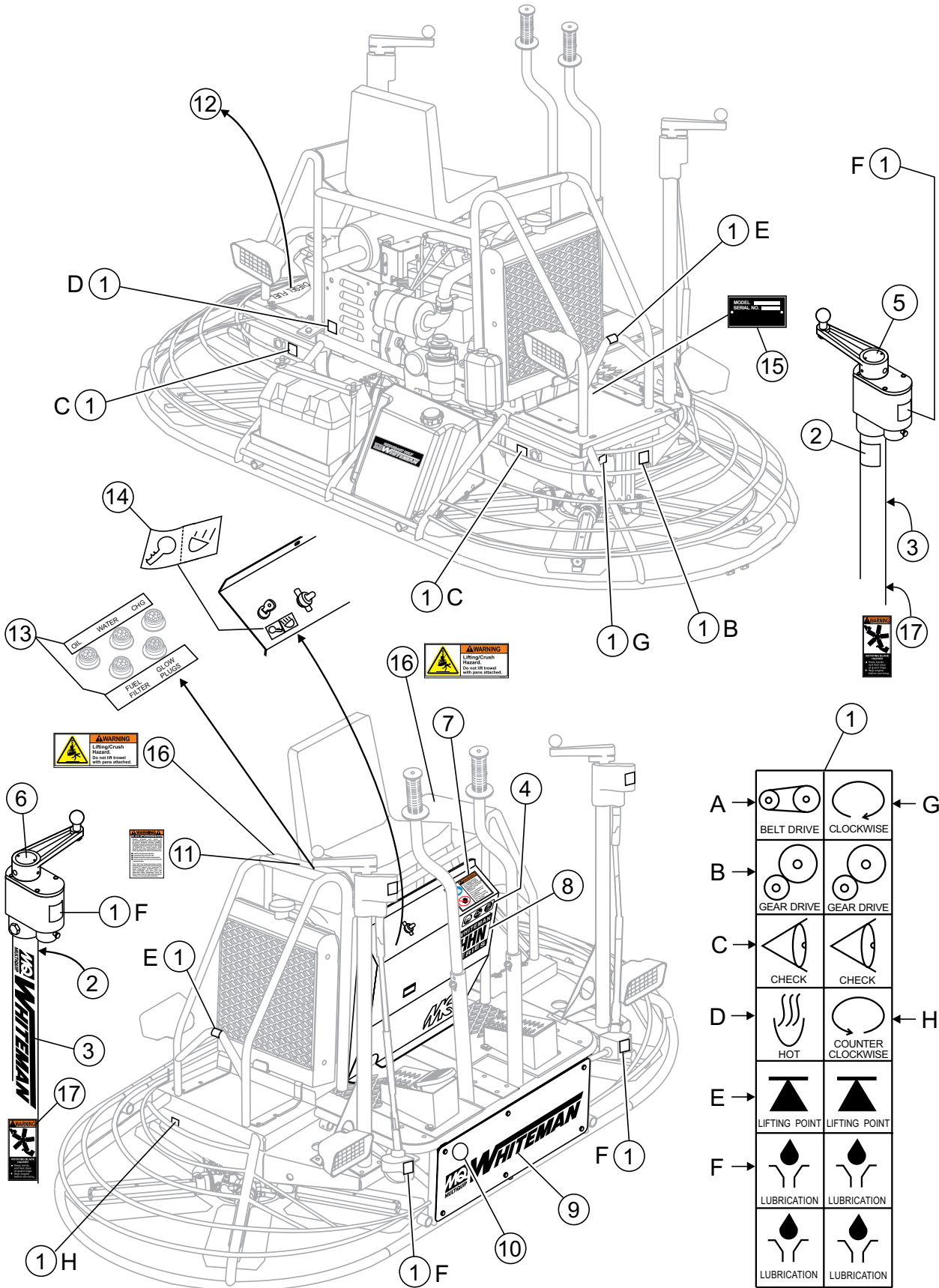

# HHN 34TVD — NAME PLATE AND DECALS

## NAMEPLATE AND DECALS

<u>NO.</u>	<u>PART NO.</u>	<u>PART NAME</u>	<u>QTY.</u>	<u>REMARKS</u>
1	11246	DECAL SET, INTERNATIONAL STDS.....	1.....	SAFETY ITEM
2	2634	DECAL, SPRING SAFETY .....	2.....	SAFETY ITEM
3	1499	DECAL, MQ-WHITEMAN RED/TOWER	2	
4	36099	DECAL, SAFETY CLOTHING ISO BLUE .....	1.....	REPLACES 11247 SAFETY ITEM
5	2332	DECAL, AL PITCH LH	1	
6	2300	DECAL, AL PITCH RH	1	
7	35137	DECAL, READ OPERATOR'S MANUAL.....	1.....	SAFETY ITEM
8	20926	DECAL, HHN SERIES	1	
9	10818	DECAL, MQ-WHITEMAN 24 X 3	1	
10	13118	DECAL, POWDER COATED	1	
11	20525	DECAL, PROP 65.....	1.....	SAFETY ITEM
12	11811	DECAL, DIESEL FUEL	1	
13	21517	DECAL, INSTRUMENT LIGHT 5 LABEL	1	
14	2814	DECAL, CONTROL PANEL	1	
15		SERIAL PLATE .....	1.....	CONTACT PARTS DEPT.
16	21455	DECAL, PAN LIFT WARNING.....	2.....	SAFETY ITEM
17	35168	DECAL, BLADE WARNING .....	2.....	SAFETY ITEM

# HHN 34TVD — STEERING CONTROL HANDLES ASSY.

STEERING CONTROL HANDLES ASSY.

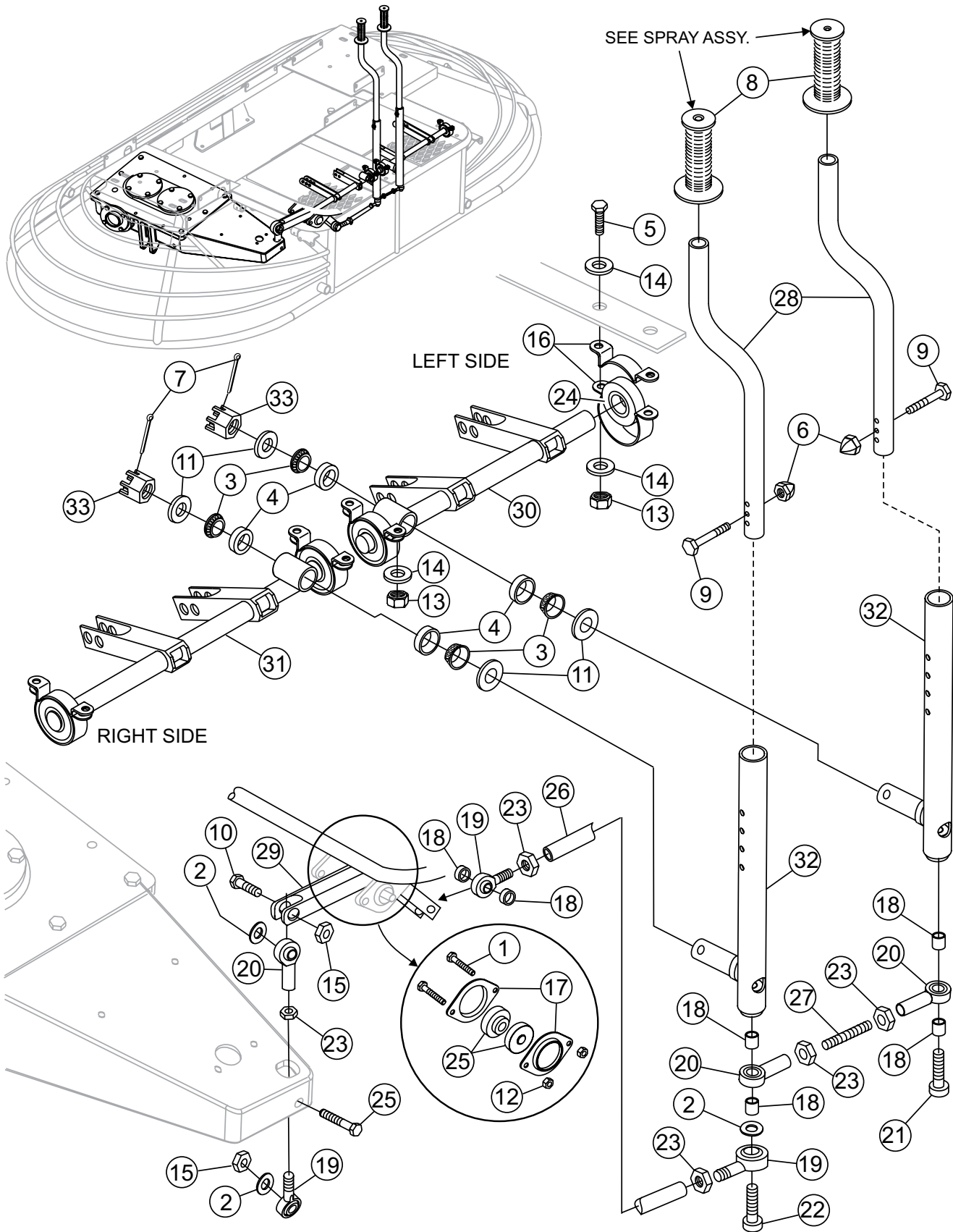

# HHN 34TVD — STEERING CONTROL HANDLES ASSY.

## STEERING CONTROL HANDLES ASSY.

<u>NO.</u>	<u>PART NO.</u>	<u>PART NAME</u>	<u>QTY.</u>	<u>REMARKS</u>
1	0131 A	SCREW, HHC 1/4-20 X 3/4	4	
2	0447	WASHER, FLAT, 1/2 SAE	3	
3	0735	BEARING, CONE, TIMKEN #A6075	4	
4	0735 A	BEARING, CUP, TIMKEN #A6157	4	
5	1023	SCREW, HHC 3/8-16 X 1-1/4	8	
6	2197	NUT, ACORN 1/4-20	2	
7	2219	PIN, COTTER 1/8 X 1 1/2	2	
8	2267	GRIP HANDLE, LEFT-RIGHT	2	
9	5277	SCREW, HHC 1/4-20 X 1 1/2	2	
10	EM 963105	SCREW, HHC 1/2-13 X 2.....	2.....	REPLACES 6159A
11	8151	WASHER, FLAT, 3/4 SAE	4	
12	10024	NUT, NYLOC 1/4-20	4	
13	10133	NUT, NYLOC 3/8-16	8	
14	10136	WASHER, FLAT, 3/8 SAE	16	
15	10176	NUT, NYLOC 1/2-13	4	
16	11138	BEARING, P-BLOCK HOUSING 47MPB	4	
17	11139	HOUSING SET, BEARING FLANGE 40M-2	6	
18	11141	SPACER, ROD END	6	
19	11142	ROD END, 1/2-20 MALE RH	3	
20	11143	ROD END, 1/2-20 FEMALE RH	3	
21	11144	SCREW, SHC 1/2-20 X 2 PLTD	1	
22	11145	SCREW, SHC 1/2-20 X 3 PLTD	1	
23	11146	NUT, HEX JAM 1/2-20	5	
24	11149	BEARING, SB-204-12	4	
25	11150	BEARING, SB-201-B	6	
26	11172	ROD, L/R MOTION CONTROL	1	
27	11173	THREADPIECE, 1/2-20 X 2 PLTD	1	
28	11177	HANDLE TUBE, UPPER	2	
29	12193	LEVER, L/R MOTION	1	
30	12903	STEERING CONTROL W/A LS ASSIST	1	
31	12904	STEERING CONTROL W/A RS ASSIST	1	
32	12425	HANDLE , LOWER W/A	2	
33	12426	NUT, SLOTTED 3/4-16 PLATED	2	

# HHN 34TVD — STEERING CONTROL (ASSIST) ASSY.

## STEERING CONTROL (ASSIST) ASSY.

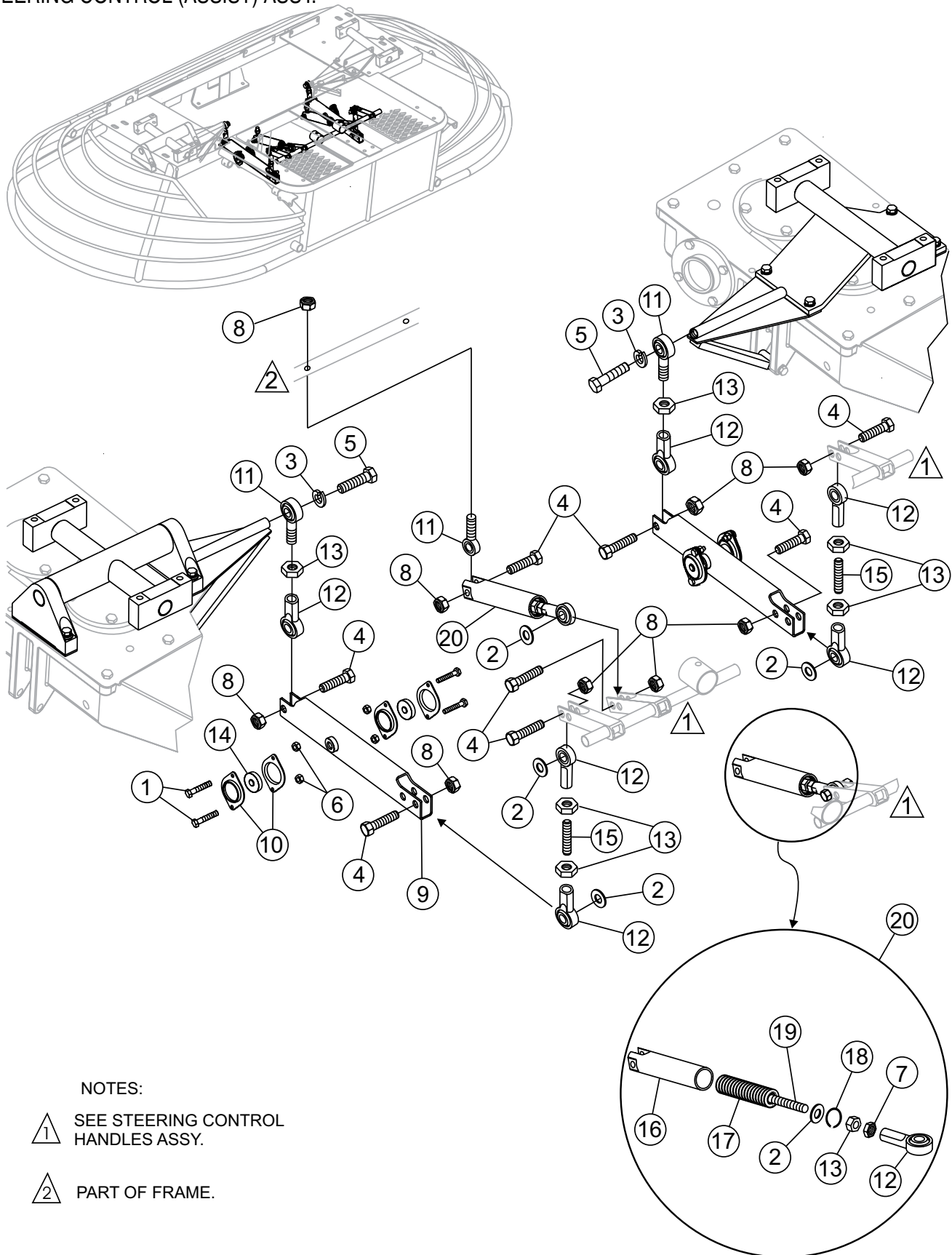

NOTES:

1 SEE STEERING CONTROL HANDLES ASSY.

2 PART OF FRAME.

# HHN 34TVD — STEERING CONTROL (ASSIST) ASSY.

## STEERING CONTROL (ASSIST) ASSY.

<u>NO.</u>	<u>PART NO.</u>	<u>PART NAME</u>	<u>QTY.</u>	<u>REMARKS</u>
1	0131 A	SCREW, HHC 1/4-20 X 3/4	12	
2	0447	WASHER, FLAT, 1/2 SAE	12	
3	5054 A	WASHER, LOCK, 1/2 MED.	2	
4	EM 963105	SCREW, HHC 1/2-13 X 2.....	13.....	REPLACES 6159A
5	8136	SCREW, HHC 1/2-20 X 1.1/2"	2	
6	10024	NUT, NYLOC 1/4-20	16	
7	10087	NUT, NYLOC 1/2-20 THIN	2	
8	10176	NUT, NYLOC 1/2-13	13	
9	11127	LEVER, STEERING CONTROL W/A	2	
10	11139	BEARING, FLANGE HOUSING 40M-2	6	
11	11142	ROD END, 1/2-20 MALE RH	9	
12	11143	ROD END, 1/2-20 FEMALE RH	7	
13	11146	NUT, HEX JAM 1/2-20	11	
14	11150	BEARING, SB-201-8	6	
15	11173	THREADPIECE, STEERING LEVERS	2	
16	12195	HOUSING, STEERING ASSIST SPRING	2	
17	12196	SPRING, STEERING ASSIST	2	
18	12197	RING, RETAINING	2	
19	12198	SCREW, HHC 1/2-20 X 7 TAP GR5	2	
20	12200	ASSIST ASSY. , STEERING	2	

# HHN 34TVD — GEAR BOX/PIVOT ASSY.

## GEAR BOX/PIVOT ASSY.

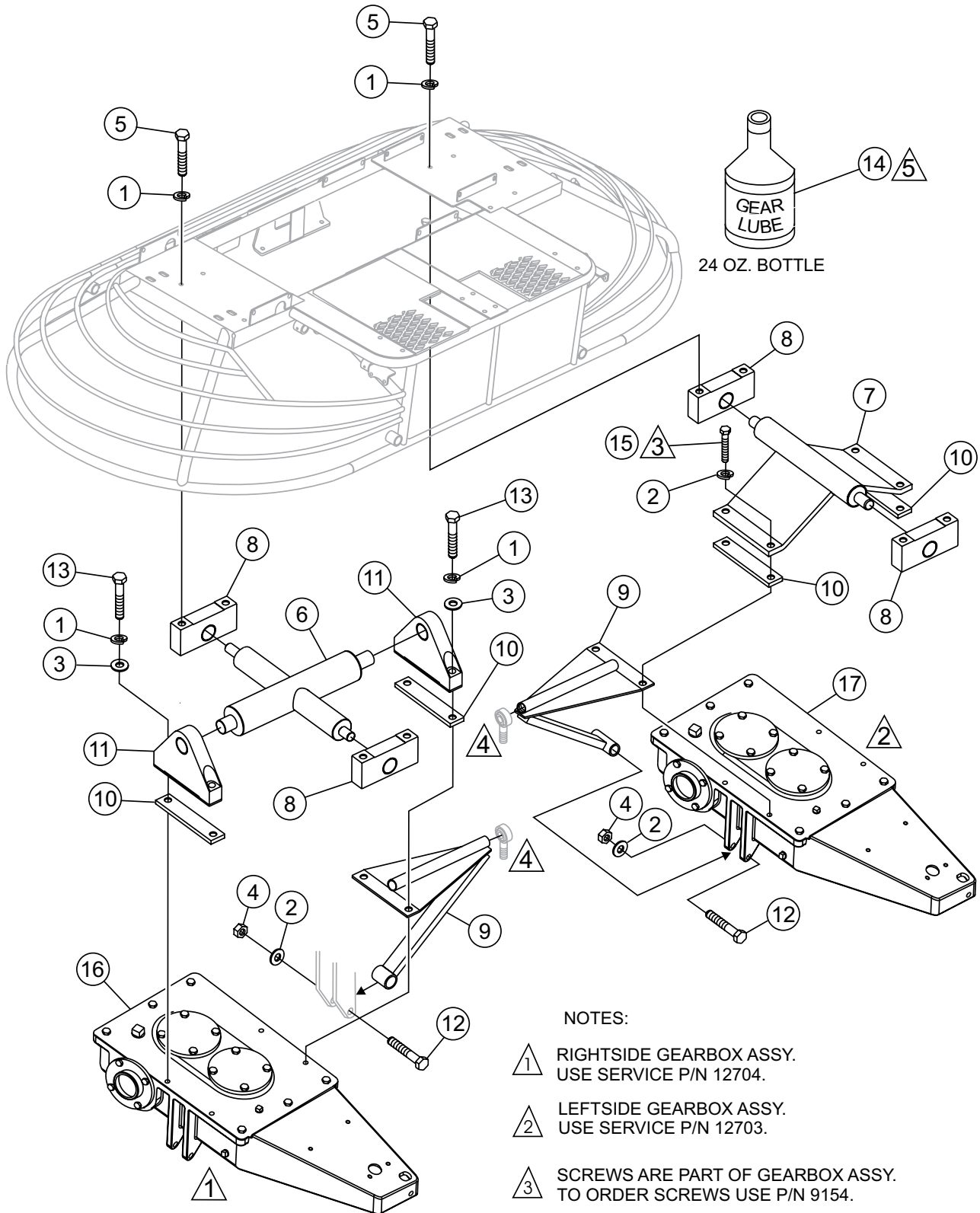

### NOTES:

- ① RIGHTSIDE GEARBOX ASSY.  
USE SERVICE P/N 12704.
- ② LEFTSIDE GEARBOX ASSY.  
USE SERVICE P/N 12703.
- ③ SCREWS ARE PART OF GEARBOX ASSY.  
TO ORDER SCREWS USE P/N 9154.
- ④ SEE STEERING CONTROL ASSY.
- ⑤ EACH GEARBOX CAPACITY 144 OZ. (4.26 LITERS)  
USE ISO 220 AGMA GR 5EP GEAR COMPOUND.

# HHN 34TVD — GEAR BOX/PIVOT ASSY.

## GEAR BOX/PIVOT ASSY.

<u>NO.</u>	<u>PART NO.</u>	<u>PART NAME</u>	<u>QTY.</u>	<u>REMARKS</u>
1	0166 A	WASHER, LOCK 3/8 MED	8	
2	0447	WASHER, FLAT 1/2 SAE	2	
3	10136	WASHER, FLAT 3/8 SAE	4	
4	10176	NUT, NYLOC 1/2-13	2	
5	1023	SCREW, HHC 3/8 -16 X 1-1/4	8	
6	12716	TRUNNION	1	
7	12719	PIVOT, GEAR BOX W/A	1	
8	12725	BLOCK, ROCKER	4	
9	12856	BRACKET, DIRECTION CONTROL	1	
10	12859	PLATE G.B. SPACER	4	
11	12713	ROCKER BLOCK	2	
12	2549	SCREW, HHC 1/2-13 X 3	2	
13	4370	SCREW, HHC 3/8-16 X 2-1/4	4	
14	20445	GEARLUBE, ISO 220 AGMA GR 5EP 24 OZ.	6	
15#	9154	SCREW, HHC 3/8-16 X 1-3/4	4	
16	12704	GEARBOX, RIGHT .....	1.....	INCLUDES ITEMS W/#
17	12703	GEARBOX, LEFT .....	1.....	INCLUDES ITEMS W/#

# HHN 34TVD — GEARBOX ASSY.

## GEARBOX ASSY.

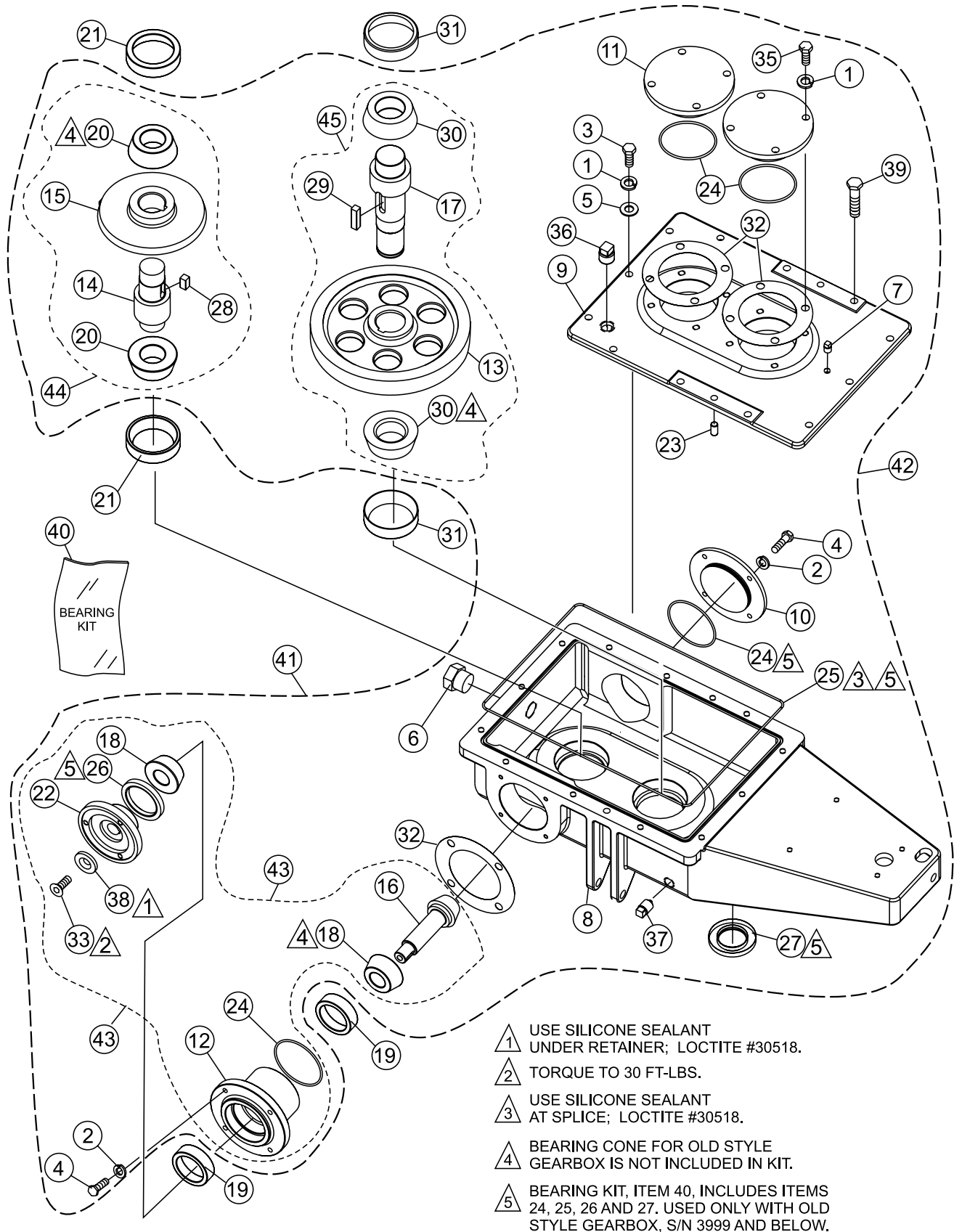

- ▲ 1 USE SILICONE SEALANT UNDER RETAINER; LOCTITE #30518.
- ▲ 2 TORQUE TO 30 FT-LBS.
- ▲ 3 USE SILICONE SEALANT AT SPLICE; LOCTITE #30518.
- ▲ 4 BEARING CONE FOR OLD STYLE GEARBOX IS NOT INCLUDED IN KIT.
- ▲ 5 BEARING KIT, ITEM 40, INCLUDES ITEMS 24, 25, 26 AND 27. USED ONLY WITH OLD STYLE GEARBOX, S/N 3999 AND BELOW.

# HHN 34TVD — GEARBOX ASSY.

## GEARBOX ASSY.

<u>NO.</u>	<u>PART NO.</u>	<u>PART NAME</u>	<u>QTY.</u>	<u>REMARKS</u>
1\$	0166 A	WASHER, LOCK 3/8 MED	16	
2\$	0181 B	WASHER, LOCK 1/4 MED	8	
3\$	0205	SCREW, HHC 3/8-16 X 1	8	
4\$	0730	SCREW, HHC 1/4-20 X 1	8	
5\$	10136	WASHER, FLAT, 3/8 SAE	8	
6\$	11584	SIGHT GLASS, 3/4 MALE PIPE	1	
7\$	11682	FITTING, PLUG, 1/8 MP SQ HEAD	1	
8\$	12599	CASE, GEAR MACHINED	1	
9\$	12600	COVER, GEARBOX.....	1.....	OLD STYLE GEARBOX
9\$	21811	COVER, GEARBOX.....	1.....	NEW STYLE GEARBOX
10\$	12601	CAP, GEARBOX INPUT	1	
11\$	12602	CAP, GEARBOX IDLER	2	
12\$%		HUB, INPUT SHAFT.....	1.....	NOT AVAILABLE SEPARATELY
13\$+		GEAR, 85T HELICAL.....	1.....	NOT AVAILABLE SEPARATELY
14\$@		PINION, 17T HELICAL.....	1.....	NOT AVAILABLE SEPARATELY
15\$@		GEAR, 60T HELICAL.....	1.....	NOT AVAILABLE SEPARATELY
16\$%		PINION, 15T BEVEL.....	1.....	NOT AVAILABLE SEPARATELY
17\$+		SHAFT, OUTPUT.....	1.....	NOT AVAILABLE SEPARATELY
18	12691	BEARING, CONE TIMKEN #M84249.....	2.....	OLD STYLE GEARBOX
18\$%	21803	BEARING, CONE SKF 32305 J2.....	2.....	NEW STYLE GEARBOX
19	12692	BEARING, CUP TIMKEN #M84210.....	2.....	OLD STYLE GEARBOX
20	12693	BEARING, CONE TIMKEN #2793.....	2.....	OLD STYLE GEARBOX
20\$@	21802	BEARING, CONE SKF 32307 J2.....	2.....	NEW STYLE GEARBOX
21	12694	BEARING, CUP TIMKEN #2729.....	2.....	OLD STYLE GEARBOX
22\$%	12696	COUPLER, GEARBOX	1	
23\$	12697	PIN, DOWEL 0.375/.3752 X 3/4	2	
24\$%#	12698	O RING, SIZE - 151 BUNA N	4	
25\$#	12700	SEAL, CASE O-RING HHN 0.103 X 46.38	1	
26\$%#	12701	SEAL, NATIONAL #471424	1	
27\$#	12702	SEAL, NATIONAL #470682	1	
28\$@	12735	KEY, 3/8 X 3/4	1	
29\$+	12736	KEY, HARDENED 3/8 X 1-1/2	1	
30	12796	BEARING, CONE TIMKEN #26882.....	2.....	OLD STYLE GEARBOX
30\$+	21801	BEARING, CONE SKF 33109 Q.....	2.....	NEW STYLE GEARBOX
31	12797	BEARING, CUP TIMKEN #26823.....	2.....	OLD STYLE GEARBOX
32\$	20932	SHIM, INPUT. 0.002 THICK	3	
33\$%	1313	SCREW, FHSC 3/8 - 24 X 3/4 PLAIN	1	
34\$%	26034	KEY, 3/16 X 17/32	1	
35\$	4196	SCREW, HHC 3/8 - 16 X 3/4	8	
36\$	911064	FITTING, PLUG 1/2 MP SQ HEAD	1	
37\$	911329	FITTING, PLUG 3/8 MP MAGNETIC	2	
38\$%	9120	RETAINER, DRIVEN PULLEY	1	
39\$	9154	SCREW, HHC 3/8 - 16 X 1-3/4	4	
40	20933	KIT, BEARING/SEAL HHN HELICAL.....	1.....	INCLUDES ITEMS W/ #
		.....		GEARBOX S/N 3999 AND BELOW
41	21854	GEARBOX ASSY., RIGHT.....	1.....	INCLUDES ITEMS W/ \$
42	21853	GEARBOX ASSY., LEFT.....	1.....	INCLUDES ITEMS W/ \$
43	21853854INPUT	KIT, INPUT PINION/HUB/COUPLER.....	1.....	INCLUDES ITEMS W/ %
44	21853854INTER	KIT, INTER PINION/GEAR	1	INCLUDES ITEMS W/ @
45	21853854OUTER	KIT, OUTPUT SHAFT/GEAR	1	INCLUDES ITEMS W/ +

# HHN 34TVD — TWIN PITCH HANDLE ASSY. (LEFT & RIGHT)

TWIN PITCH HANDLE ASSY. (LEFT & RIGHT)

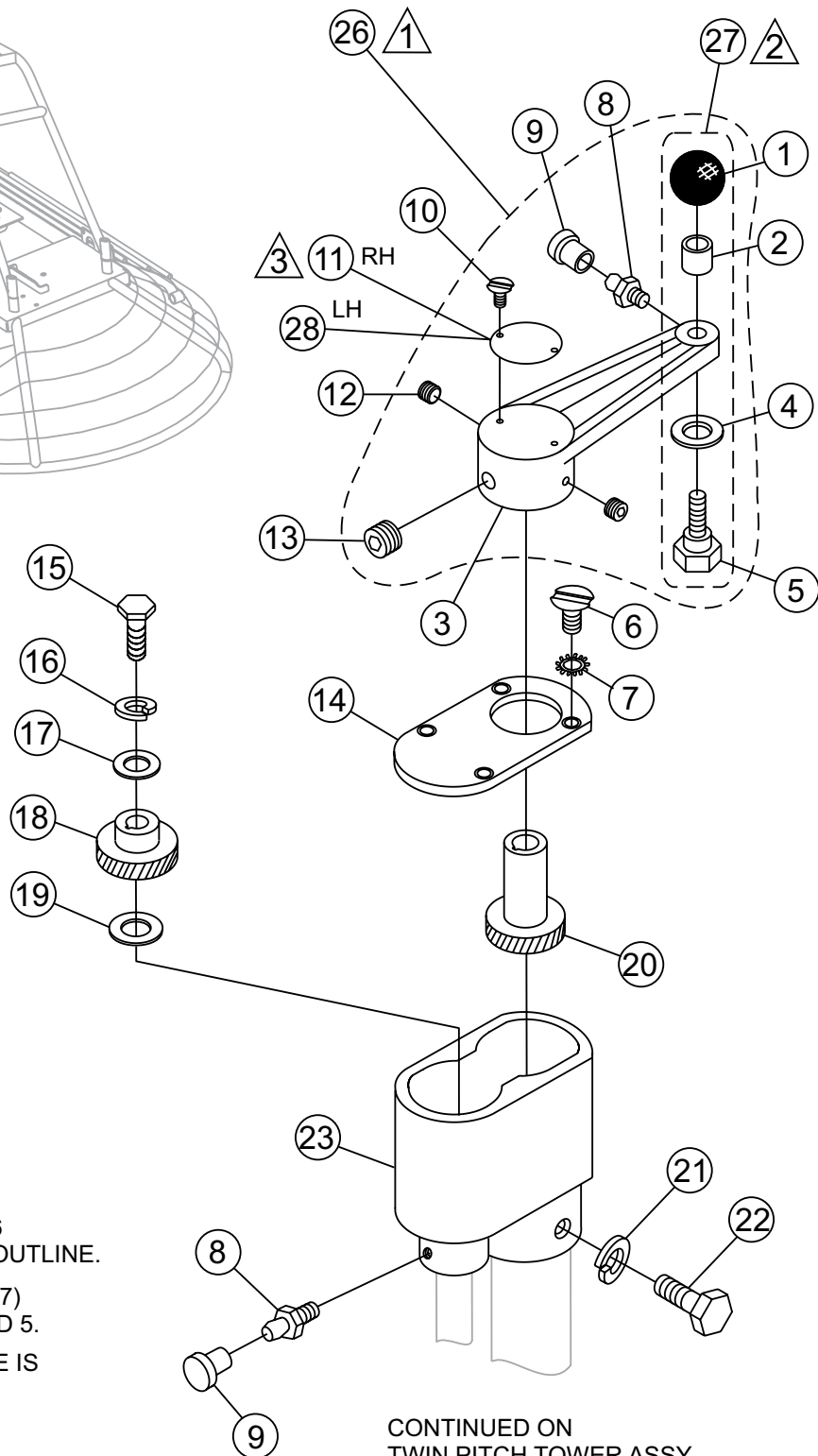
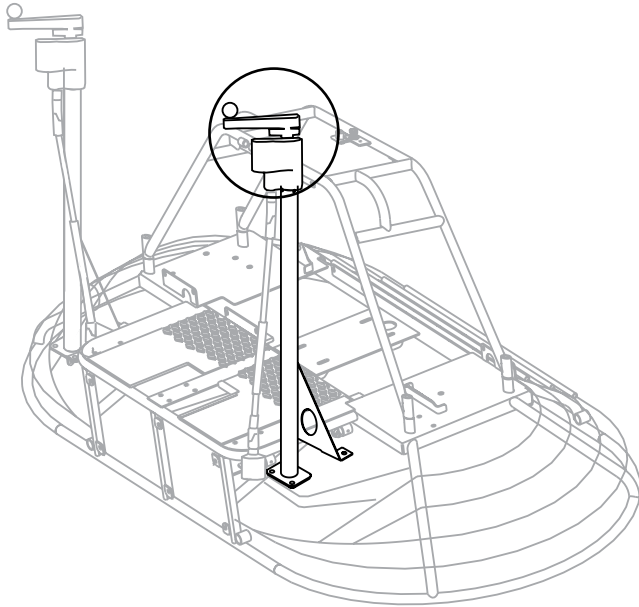

- ▲ 1 LEVER ASSEMBLY, ITEM 26 INCLUDES ITEMS WITHIN OUTLINE.
- ▲ 2 KNOB KIT P/N 2737 (ITEM 27) INCLUDES ITEMS 1,2,4, AND 5.
- ▲ 3 RIGHT SIDE PITCH HANDLE IS IDENTICAL TO LEFT SIDE PITCH HANDLE UNLESS OTHERWISE NOTED.

CONTINUED ON  
TWIN PITCH TOWER ASSY.

# HHN 34TVD — TWIN PITCH HANDLE ASSY. (LEFT & RIGHT)

## TWIN PITCH HANDLE ASSY. (LEFT & RIGHT)

<u>NO.</u>	<u>PART NO.</u>	<u>PART NAME</u>	<u>QTY.</u>	<u>REMARKS</u>
1 #	4403	KNOB, SHIFT	1	
2 #	3231	SPACER	1	
3 #	1615	CRANK LEVER	1	
4 #	1733	HARDENED WASHER	1	
5 #	1616	SHOULDER BOLT	1	
6 +%	2620	SCREW, BHC 10 – 24 X 5/8	4	
7	10114	WASHER, EXT. SHKP, #8	4	
8	2621	FITTING GREASE	2	
9	1162 A	CAP, GREASE ZERK/2	2	
10 #	4014	SCREW, 2 - 3/16 P-K TYPE U DRIVE	2	
11 #	2300	DECAL, AL PITCH, RH	1	
12 #	1528	SCREW, SHSS 1/4 – 20 X 5/16"	2	
13 #	0185	SCREW, SHSS 3/8 – 16 X 3/8"	1	
14 +%	2649	COVER, PITCH CONT HOUSING	1	
15 +%	1579	SCREW, HHC 1/4 – 20 X 1/2	1	
16 +%	0181 B	WASHER, LOCK, 1/4 MED	4	
17 +%	0948	WASHER, FLAT, 1/4 SAE	1	
18 +%	1530	GEAR, SLAVE, TPC	1	
19 +%	1733	WASHER, 1/32 X 1/2 HARDENED	8	
20 +%	1529	GEAR, MASTER, TPC	1	
21 +%	0161 C	WASHER, LOCK 5/16 MED	1	
22 +%	0655	SCREW, HHC 5/16 – 18 X 3/4	1	
23 +%	10546	HOUSING, PITCH CONTROL, 1 - 3/4	1	
26	1617	LEVER ASSY., TROWEL ADJUSTMENT .....	1	INCLUDES ITEMS W/#
27	2737	KNOB, KIT .....	1	INCLUDES ITEMS W/\$
28 #	2332	DECAL, AL PITCH, LH	1	

NOTE 1: ITEMS WITH % ARE PART OF TWIN PITCH ASSEMBLY RIGHT SIDE P/N 20007.  
 ITEMS WITH + ARE PART OF TWIN PITCH ASSEMBLY LEFT SIDE P/N 20006.

NOTE 2: INDICATED QUANTITIES ARE FOR ONE PITCH TOWER.  
 IF ORDERING FOR TWO PITCH TOWERS DOUBLE THE QUANTITY.

# HHN34TVD — TWIN PITCH TOWER ASSY. (LEFT & RIGHT)

TWIN PITCH TOWER ASSY. (LEFT & RIGHT)

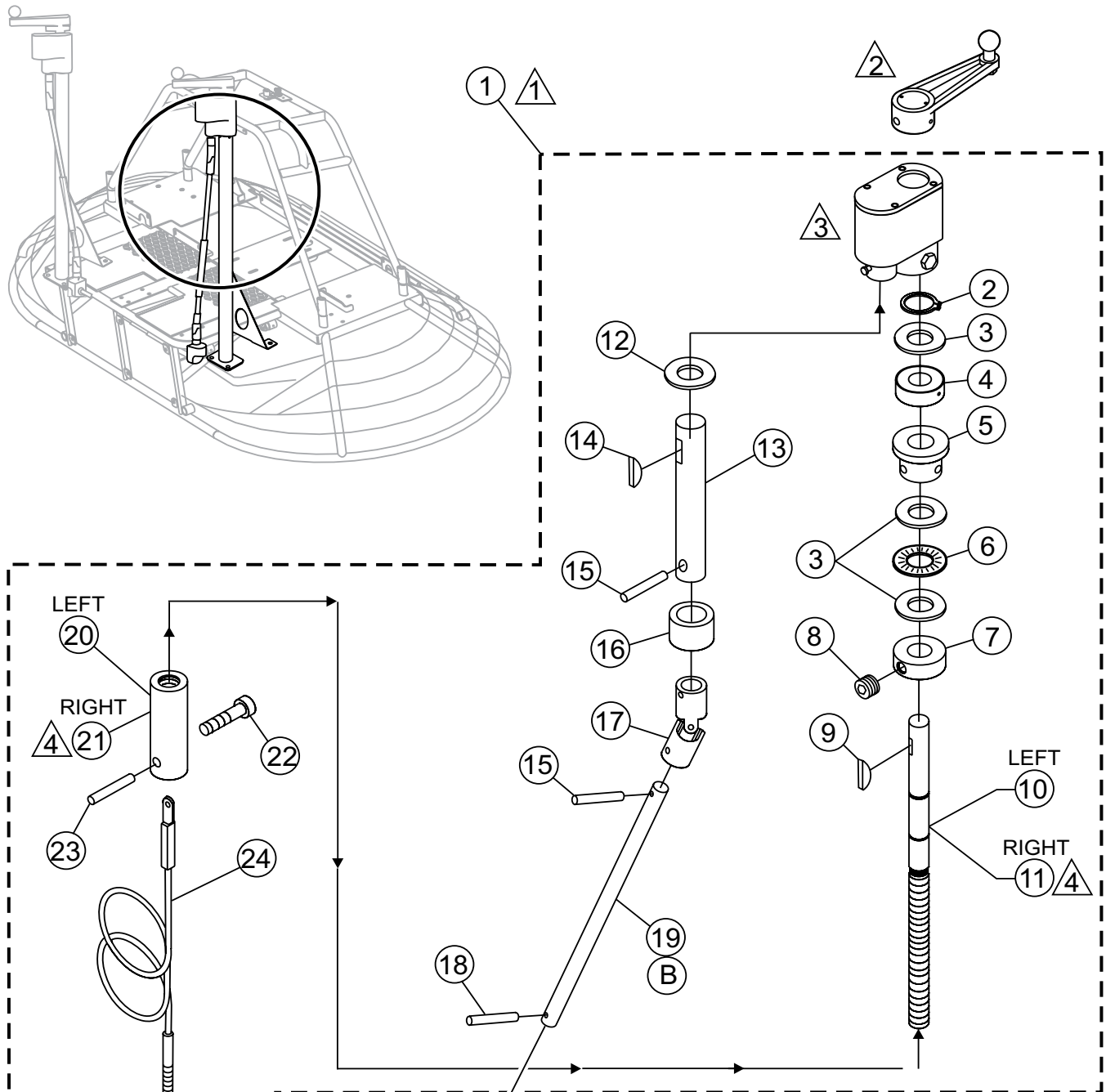

SEE (A), ITEM 32  
TWIN PITCH MITER ASSY.

SEE (B), ITEM 31  
TWIN PITCH MITER ASSY.

- 1 RIGHT SIDE TOWER ASM P/N 20007 AND LEFT SIDE TOWER ASM P/N 20006 INCL. ALL ITEMS WITHIN OUTLINE.
- 2 KNOB KIT P/N 2737, SEE TWIN PITCH HANDLE ASSY. ITEM 26.
- 3 PITCH HANDLE HOUSING COMPONENTS, TWIN PITCH HANDLE ASSY.
- 4 RIGHT SIDE TWIN PITCH ASSEMBLY IS IDENTICAL TO LEFT SIDE TWIN PITCH ASSEMBLY UNLESS OTHERWISE NOTED.

# HHN34TVD — TWIN PITCH TOWER ASSY. (LEFT & RIGHT)

## TWIN PITCH TOWER ASSY. (LEFT & RIGHT)

<u>NO.</u>	<u>PART NO.</u>	<u>PART NAME</u>	<u>QTY.</u>	<u>REMARKS</u>
1 (LT)	20006	TOWER ASSEMBLY, LEFT TPC.....	1	INCLUDES ITEMS W/+
1 (RT)	20007	TOWER ASSEMBLY, RIGHT TPC.....	1	INCLUDES ITEMS W/%
2 +%	10512	RING, SNAP, TRUARC 5160 – 75	1	
3 +%	2170	BEARING, RACE, TORR #TRA 1220	3	
4 +%	1604	BEARING, BALL THRUST	1	
5 +%	1612	BEARING, ALUM – PITCH CONTR	1	
6 +%	2169	BEARING, THRUST, TORR #NTA 1220	1	
7 +%	2367	SET COLLAR.....	1	INCLUDES ITEM 8
8 +%	0685	SCREW, SHS 5/16 - 18 X 5/16	1	
9 +%	0126	KEY, WOODRUFF #9	1	
10 +	10511	SHAFT, PITCH CONTROL, LH TPC.....	1	LEFT SIDE ONLY
11 %	10510	SHAFT, PITCH CONTROL, RH TPC.....	1	RIGHT SIDE ONLY
12 +%	1733	WASHER, 1/32 X 1/2 HARDENED	4	
13 +%	2007	SHAFT	1	
14 +%	1578	KEY, WOODRUFF, #3 .....	9	QTY. INCLUDES USAGE ON ..... BOTH TWIN PITCH ASSEMBLIES, ..... AND MITER BOX SHAFTS
15 +%	11654	PIN, ROLL 1/8 X 1 PLATED.....	5	QTY. INCLUDES USAGE ON BOTH ..... TWIN PITCH ASSEMBLIES, AND ..... MITER BOX SHAFTS
16 +%	2311	SPACER, 3/4 X 1/2 X 0.8L	1	
17 +%	11583	U-JOINT, PITCH CONTROL	1	
18 +%	1586	PIN, ROLL 1/8 X 3/4	1	
19 +%	20005	SHAFT, PITCH CONTROL	1	
20 +	10722	SLIDE BLOCK, LH PITCH CONTROL .....	1	LEFT SIDE ONLY
21 %	10721	SLIDE BLOCK, RH PITCH CONTROL.....	1	RIGHT SIDE ONLY
22 +%	10382	BOLT, SHOULDER 3/8 X 3/8 LONG	1	
23 +%	10723	PIN, SPIROL 3/16 X 1 3/8 HD	1	
24 +%	12460	CABLE, PITCH ASSEMBLY	1	
25 +%	1116	NUT, BRASS JAM 5/16 – 18	2	

NOTE 1: ITEMS WITH % ARE PART OF TWIN PITCH ASSEMBLY RIGHT SIDE P/N 20007.  
 ITEMS WITH + ARE PART OF TWIN PITCH ASSEMBLY LEFT SIDE P/N 20006.

NOTE 2: INDICATED QUANTITIES ARE FOR ONE PITCH TOWER.  
 IF ORDERING FOR TWO PITCH TOWERS DOUBLE THE QUANTITY.

# HHN34TVD — TWIN PITCH MITER ASSY. (LEFT & RIGHT)

## TWIN PITCH MITER ASSY. (LEFT & RIGHT)

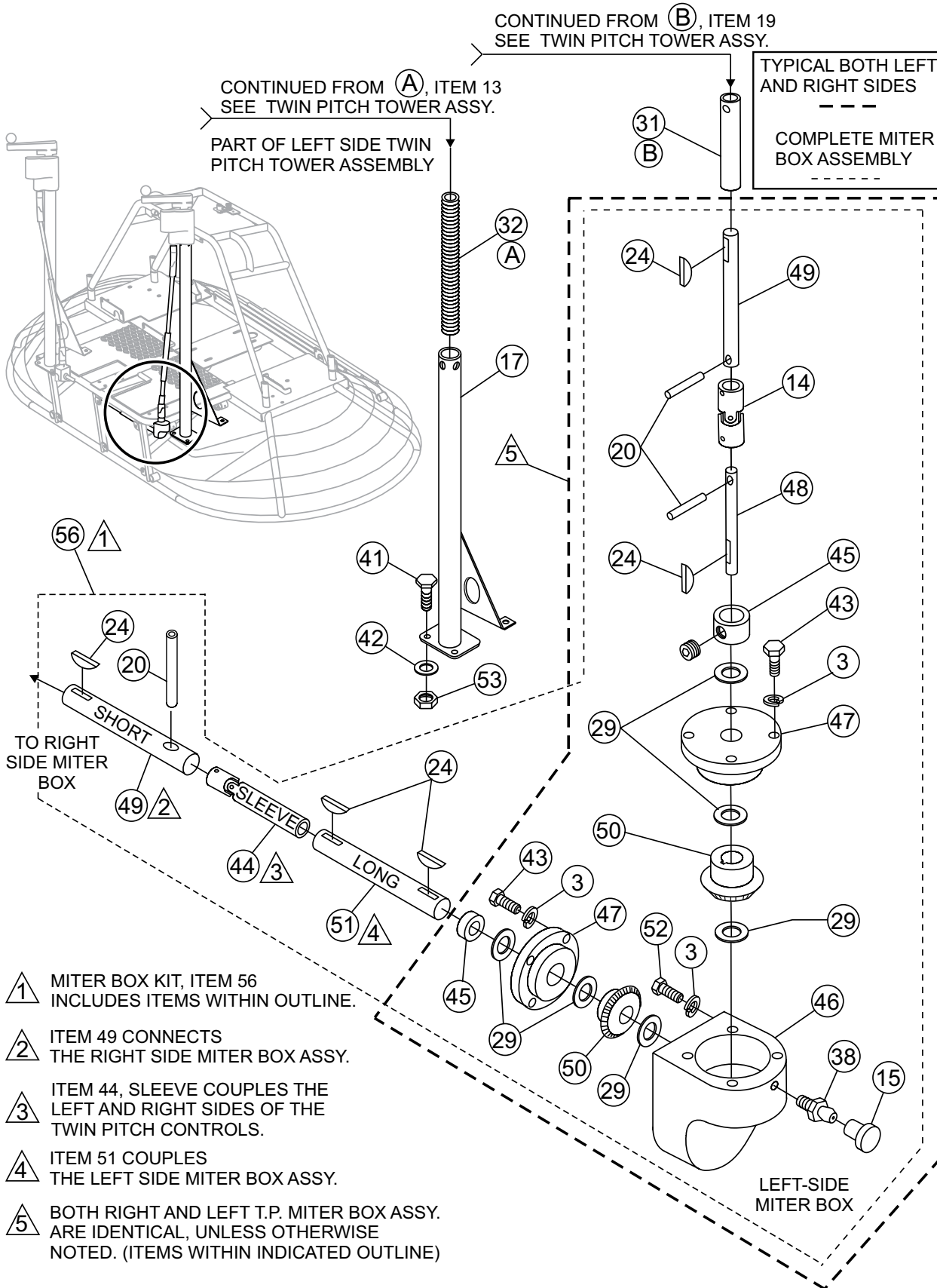

# HHN34TVD — TWIN PITCH MITER ASSY. (LEFT & RIGHT)

## TWIN PITCH MITER ASSY. (LEFT & RIGHT)

<u>NO.</u>	<u>PART NO.</u>	<u>PART NAME</u>	<u>QTY.</u>	<u>REMARKS</u>
3@+%	0181 B	WASHER, LOCK, 1/4 MED	20	
14@+%	11583	U-JOINT, PITCH CONTROL	2	
15@+%	1162 A	CAP, GREASE ZERK	2	
17	10548	TUBE, PITCH CONTROL	1	
20@+%	11654	PIN, ROLL 1/8 X 1 .....	5	QTY. INCLUDES USAGE ON BOTH TWIN PITCH ASSEMBLIES, AND MITER BOX SHAFTS
24@+%	1578	KEY, WOODRUFF, #3 .....	9	QTY. INCLUDES USAGE ON BOTH TWIN PITCH ASSEMBLIES, AND MITER BOX SHAFTS
29@+%	1733	WASHER, 1/32 X 1/2 HARDENED	8	
31	2012	SLEEVE, ADJ – LONG, RIDER	1	
32	2156	SPRING, COIL	1	
38@+%	2621	ZERK, GREASE STR 1/4 – 28	2	
41	0202	SCREW, HHC 5/16 – 18 X 1	4	
42	0300 B	WASHER, FLAT, 5/16 SAE	4	
43@	0730	SCREW, HHC 1/4 – 20 X 1	8	
44@	11653	SLEEVE, WITH U-JOINT HTH	1	
45@	1577	SET COLLAR, 1/2	2	
46@	1987	MITER BOX, PITCH CONTROL	1	
47@	1988	MITER BOX, BEARING CAP RIDERS	2	
48@	2021	SHAFT, MITER VERTICAL	1	
49@	2022	SHAFT, MITER .....	3	QTY. INCLUDES USAGE ON BOTH TWIN PITCH ASSEMBLIES, AND MITER BOX SHAFTS
50@	2062	GEAR, MITER	2	
51@	2845	SHAFT, MITER BOX HORIZ	1	
52@	4514	SCREW, HHC 1/4 – 20 X 5/8	4	
53	5283	NUT, NYLOC 5/16 –18	4	
56	11655	MITER BOX ASSEMBLY .....	1	INCLUDES ITEMS W/@

NOTE 1: ITEMS WITH % ARE PART OF TWIN PITCH ASSEMBLY RIGHT SIDE P/N 20007.  
ITEMS WITH + ARE PART OF TWIN PITCH ASSEMBLY LEFT SIDE P/N 20006.

NOTE 2: INDICATED QUANTITIES ARE FOR ONE PITCH TOWER.  
IF ORDERING FOR TWO PITCH TOWERS DOUBLE THE QUANTITY.

# HHN 34TVD — ENGINE AND MOUNTS ASSY.

ENGINE AND MOUNTS ASSY.

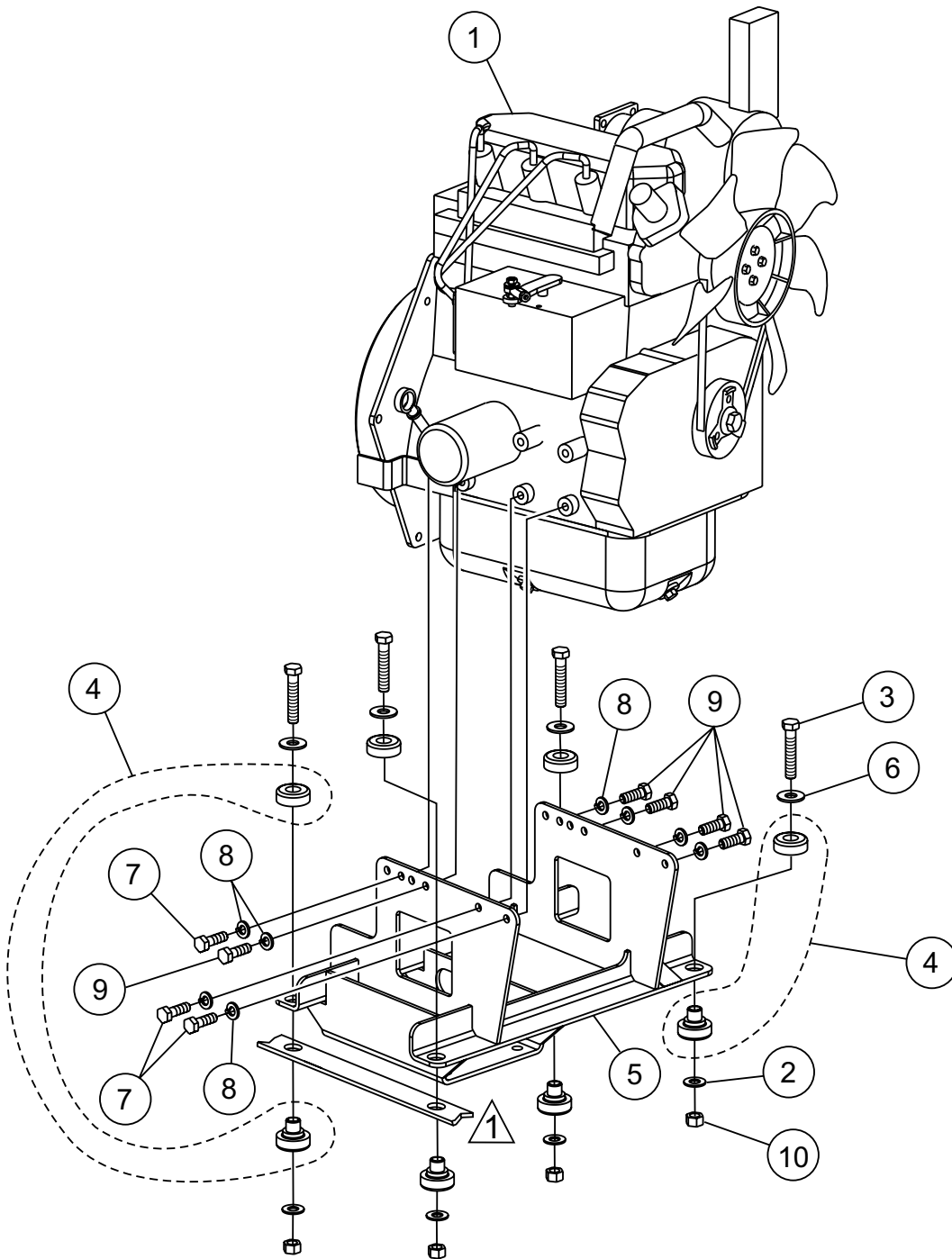

NOTES:

 PART OF FRAME.

# HHN 34TVD — ENGINE AND MOUNTS ASSY.

## ENGINE AND MOUNTS ASSY.

<u>NO.</u>	<u>PART NO.</u>	<u>PART NAME</u>	<u>QTY.</u>	<u>REMARKS</u>
1	21295	ENGINE, BRIGGS 34 HP DM954D	1	
2	10136	WASHER, FLAT 3/8 SAE	4	
3	1665	SCREW, 3/8 - 16 X 2	4	
4	21014	MOUNT, ENGINE VIB.	4	
5	21582	CRADLE, ENGINE	1	
6	4001	WASHER, FLAT 3/8 PLTD STD USS	4	
7	1605	SCREW, HHC M8 - 1.25 X 25MM	3	
8	0161 C	WASHER, LOCK 5/16 MED	8	
9	2866	SCREW, HHC M8 - 1.25 X 20MM	5	
10	10133	NUT, NYLOC 3/8 - 16	4	



# HHN 34TVD — ENGINE - AIR CLEANER & THROTTLE ASSY.

## ENGINE - AIR CLEANER & THROTTLE ASSY.

<u>NO.</u>	<u>PART NO.</u>	<u>PART NAME</u>	<u>QTY.</u>	<u>REMARKS</u>
1	0161 C	WASHER, LOCK, 5/16 MED.	5	
2	0730	SCREW, HHC 1/4 - 20 X 1	2	
3	0937	NUT, HEX 10-32	2	
4	0948	WASHER, FLAT 1/4 SAE	2	
5	10018	SCREW, SHC 10-32 X 1	1	
6	10019	NUT, NYLOC 10-32	1	
7	10434	CLAMP, HOSE 2 IN ID	2	
8	1605	SCREW, HHC M8-1.25 X 25mm	5	
9	19266	NUT, BLIND 1/4 - 20 X 10GA	2	
10	19468	GROMMET	2	
11	19470	WASHER, FLAT 5/16 USS	2	
12	21481	BRACKET, AIR CLEANER HHN 34VTD	1	
13	21496	HOSE, AIR CLEANER HHN 34VTD	1	
14	21509	SPACER, .5 OD X .05 W X .31	2	
15	2153	ROD END, 10-32 FEMALE RH	1	
16	2203	WASHER, FLAT #10	1	
17	825118	AIR CLEANER ASSY.	1	
18	820263	ELEMENT, AIR CLEANER	1	
19	820250	CLAMP, AIR CLEANER	1	
20	820314	OIL FILTER	1	

# HHN 34TVD — ENGINE RADIATOR ASSY.

## ENGINE RADIATOR ASSY.

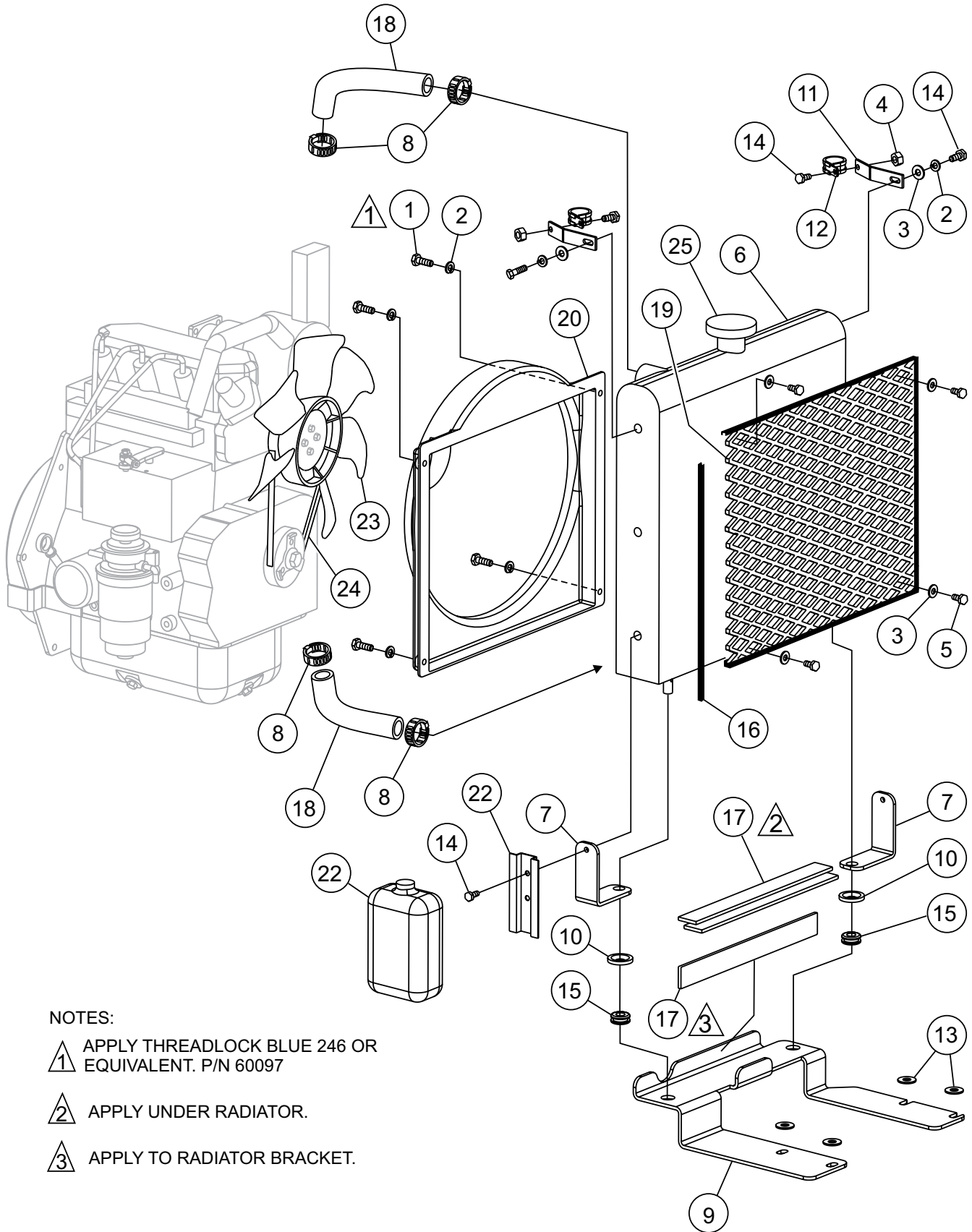

### NOTES:

1 APPLY THREADLOCK BLUE 246 OR EQUIVALENT. P/N 60097

2 APPLY UNDER RADIATOR.

3 APPLY TO RADIATOR BRACKET.

# HHN 34TVD— ENGINE RADIATOR ASSY.

## ENGINE RADIATOR ASSY.

<u>NO.</u>	<u>PART NO.</u>	<u>PART NAME</u>	<u>QTY.</u>	<u>REMARKS</u>
1	0131 A	SCREW, HHC 1/4 - 20 X 3/4	4	
2	0181 B	WASHER, LOCK 1/4 MED	6	
3	0948	WASHER, FLAT, 1/4 SAE	6	
4	10024	NUT, NYLOC 1/4-20	2	
5	1579	SCREW, HHC 1/4 - 20 X 1/2	4	
6	21453	RADIATOR, HHN 34TVD	1	
7	21281	BRACKET, RADIATOR TIE DOWN	2	
8	21552	CLAMP, HOSE WORM 1 - 1/4 DIA #16	4	
9	21568	BRACKET, RADIATOR HHN	1	
10	21570	SPACER, RADIATOR POST	2	
11	21573	BRACKET, RADIATOR SUPPORT	2	
12	21574	CLAMP, LOOP CUSHIONED #16	2	
13	4001	WASHER, FLAT 3/8 PLTD STD USS	4	
14	4514	SCREW, HHC 1/4 - 20 X 5/8	6	
15	579072	GROMMET, 0.5 ID	2	
16	60049	TRIM EDGE, 1/32.....	5.5	SOLD IN FOOT LENGTHS
17	60119	TAPE, FOAM SELF-ADH PVC 0.19 X 1.25	3	
18	825543	HOSE, RADIATOR	2	
19	12450	GUARD, RADIATOR	1	
20	21488	SHROUD, RADIATOR 34V TD.....	1	SAFETY ITEM
21	825106	BRACKET, MOUNTING TANK	1	
22	825428	TANK RESERVE ASSY.	1	
23	825446	FAN, RADIATOR	1	
24	820271	FAN BELT	1	
25	CAPPRE10415	CAP, RADIATOR	1	

# HHN 34TVD — ENGINE MUFFLER ASSY.

## ENGINE MUFFLER ASSY.

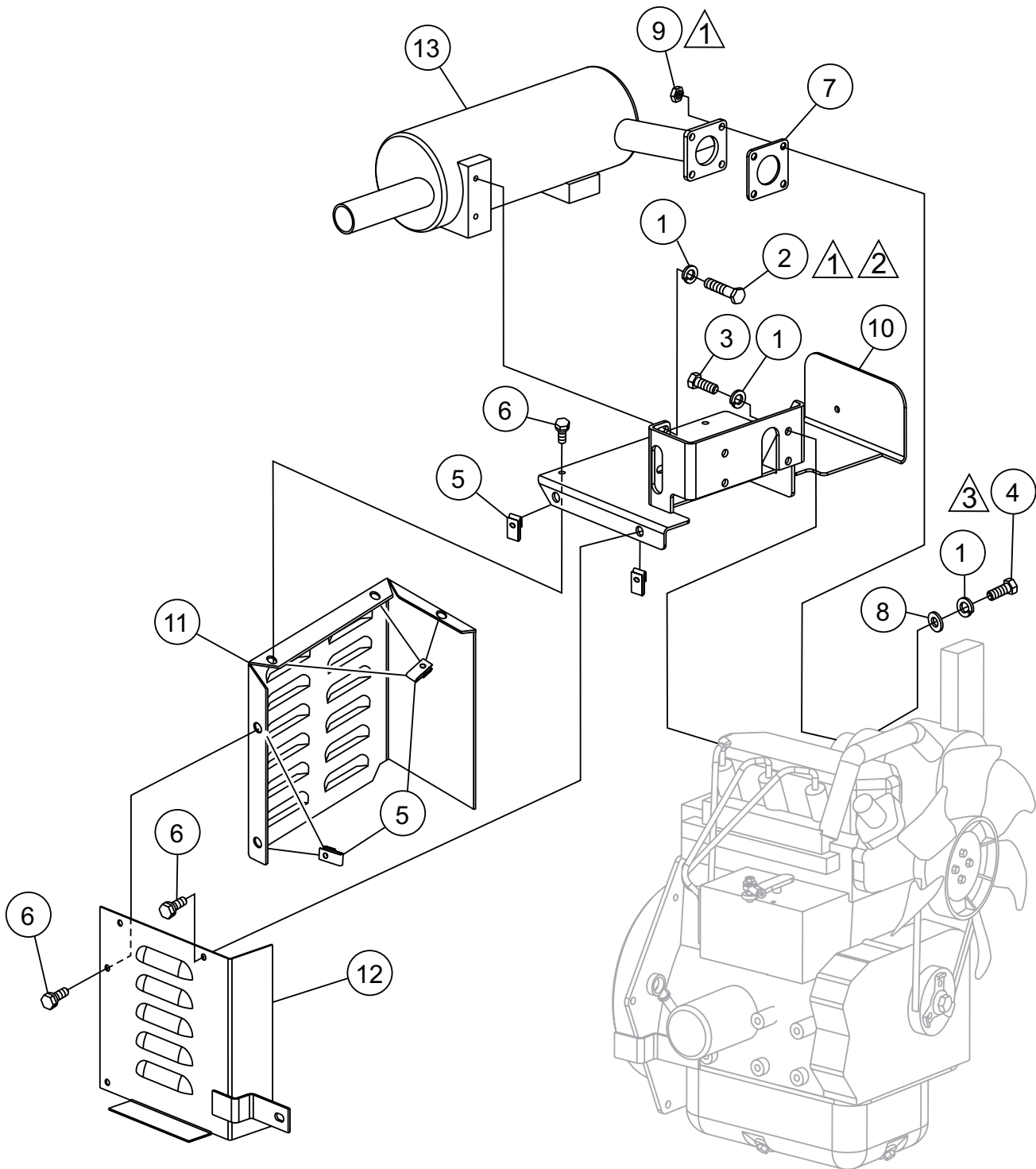

### NOTES:

① TORQUE TO 15 FT. LBS.

② USE THREADLOCK BLUE 242 OR EQUIVALENT.

③ GROUNDING HARDWARE.

# HHN 34TVD — ENGINE MUFFLER ASSY.

## ENGINE MUFFLER ASSY.

NO	PART NO	PART NAME	QTY.	REMARKS
1	0161 C	WASHER, LOCK, 5/16 MED.	4	
2	0655	SCREW, HHC 5/16-18 X 3/4	2	
3	1605	SCREW, HHC M8-1.25 X 25mm	4	
4	2866	SCREW, HHC M8-1.25 X 20mm	2	
5	11534	NUT, "U" TYPE, 1/4-20	8	
6	11819	SCREW, HHC 1/4-20 X 3/4 W/WASH	7	
7	12847	EXHAUST GASKET	1	
8	19470	WASHER, FLAT 5/16 USS	2	
9	20440	NUT, HEX LOCK M8 - 1.25 THIN	4	
10	21036	BELT GUARD/MUFFLER SUPPORT .....	1.....	SAFETY ITEM
11	21190	PLATE, BELT GUARD SIDE .....	1.....	COMET CLUTCH
		.....		SAFETY ITEM
11	22579	PLATE, BELT GUARD SIDE .....	1.....	MULTI-CLUTCH
		.....		SAFETY ITEM
12	21197	PLATE, BELT GUARD REAR.....	1.....	SAFETY ITEM
13	21451	MUFFLER, 34TVD	1	

# HHN 34TVD — ENGINE CLUTCH ASSY. (OLD STYLE)

## ENGINE CLUTCH ASSY. (OLD STYLE)

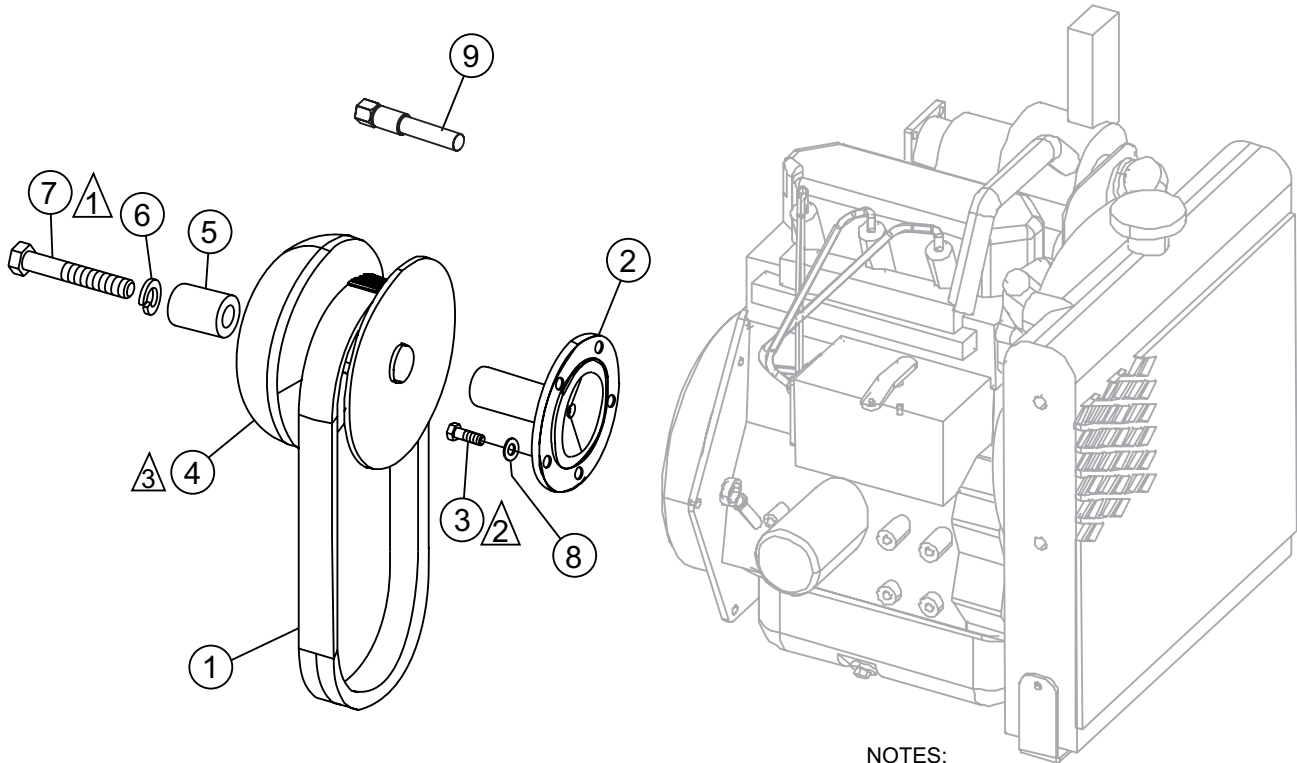

### NOTES:

- ① TORQUE TO 150 FT. LBS
- ② TORQUE TO 15 FT. LBS.  
BOLT IS INCLUDED WITH  
ENGINE.
- ③ COMET CLUTCH  
NO LONGER AVAILABLE.

# HHN 34TVD — ENGINE CLUTCH ASSY. (OLD STYLE)

## ENGINE CLUTCH ASSY. (OLD STYLE)

<u>NO.</u>	<u>PART NO.</u>	<u>PART NAME</u>	<u>QTY.</u>	<u>REMARKS</u>
1	20138	BELT, CVT-VANGUARD COMET	2	
2	3911758	FLYWHEEL STUB, B& S #835020	1	
3	20046	SCREW, HHC M8 1.25 X 25 MM GRADE 10.9	5	
4		CLUTCH, CVT 1-7/16 COMET MTLAST.....1.....	1	NO LONGER AVAILABLE USE CLUTCH KIT P/N 22581 TO UPGRADE TO MULTI-CLUTCH SYSTEM
5	20215	SPACER, 1.415 OD X 21/32 ID X 2-1/16L	1	
6	4703	WASHER, LOCK, 5/8 MED	1	
7	20057	SCREW, HHC 5/8-18 X4	1	
8	0161 C	WASHER, LOCK 5/16 MED	5	
9	23291	TOOL, CLUTCH REMOVAL	1	



MULTI-CLUTCH COMPONENTS ARE NOT INTERCHANGEABLE WITH THE PRIOR HOFFCO COMET DRIVE SYSTEM. THE HOFFCO COMET CVT SYSTEM MUST BE REPLACED FOR COMPATIBILITY WITH THE NEW EQUIPMENT.

# HHN 34TVD — ENGINE CLUTCH ASSY. (NEW STYLE)

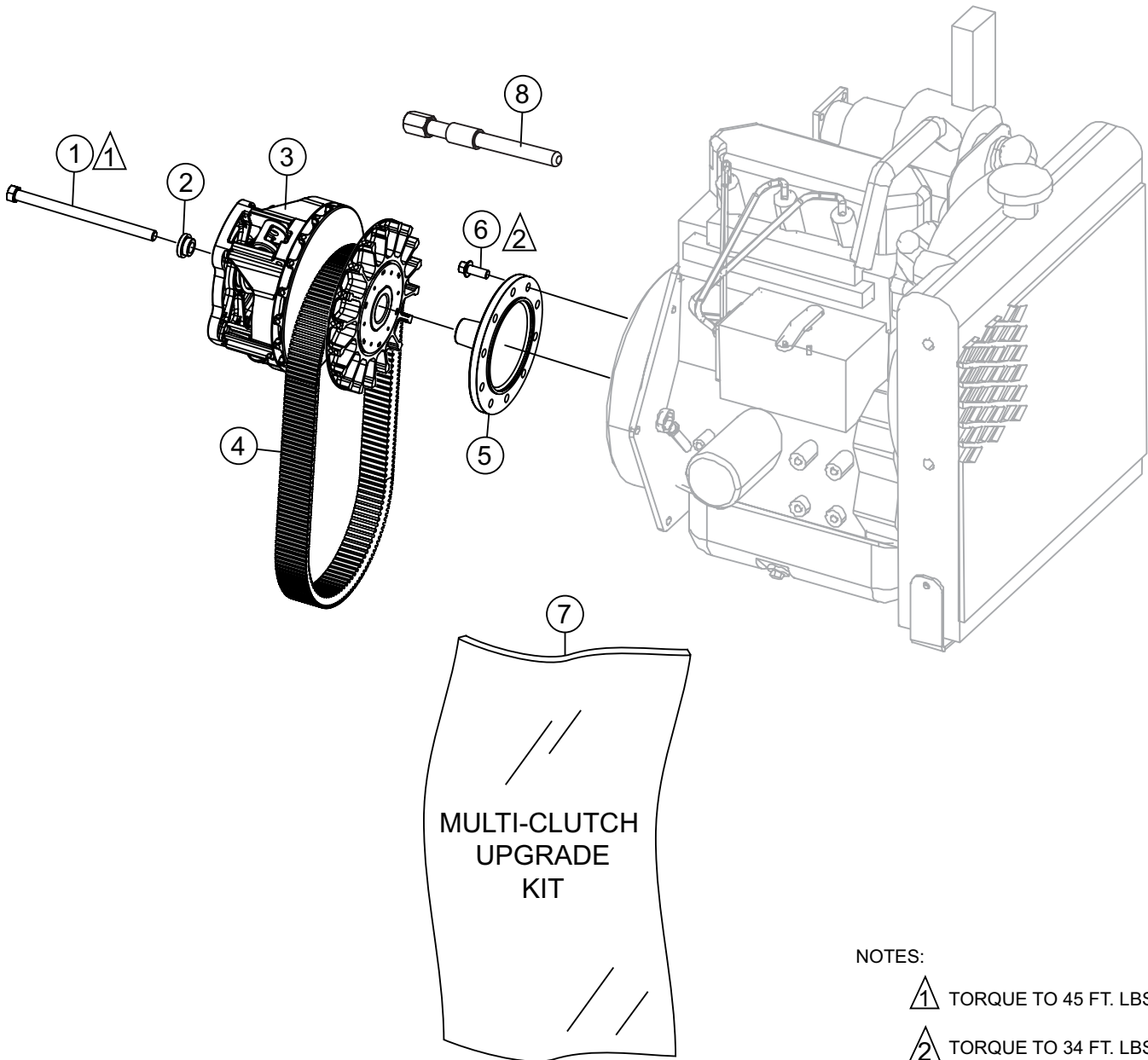

# HHN 34TVD — ENGINE CLUTCH ASSY. (NEW STYLE)

## ENGINE CLUTCH ASSY. (NEW STYLE)

<u>NO.</u>	<u>PART NO.</u>	<u>PART NAME</u>	<u>QTY.</u>	<u>REMARKS</u>
1	23377	SCREW, HHC 7/16-20 X 6.5	1	
2	23369	WASHER, STEP 7/16	1	
3	23363-1	CLUTCH, UPPER, MULTI-CLUTCH	1	
4	23365	BELT, CVT CLUTCH	2	
5	23368	STUB SHAFT	1	
6	22021	SCREW, HEX FLANGE M8	5	
7	22581	KIT, HHN CVT REPLACEMENT	1	
8	23371	PULLER, MULTI-CLUTCH	1	

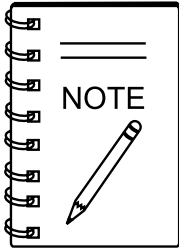

MULTI-CLUTCH COMPONENTS ARE NOT INTERCHANGEABLE WITH THE PRIOR HOFFCO COMET DRIVE SYSTEM. THE HOFFCO COMET CVT SYSTEM MUST BE REPLACED FOR COMPATIBILITY WITH THE NEW EQUIPMENT.

# HHN 34TVD — FUEL ASSY.

FUEL ASSY.

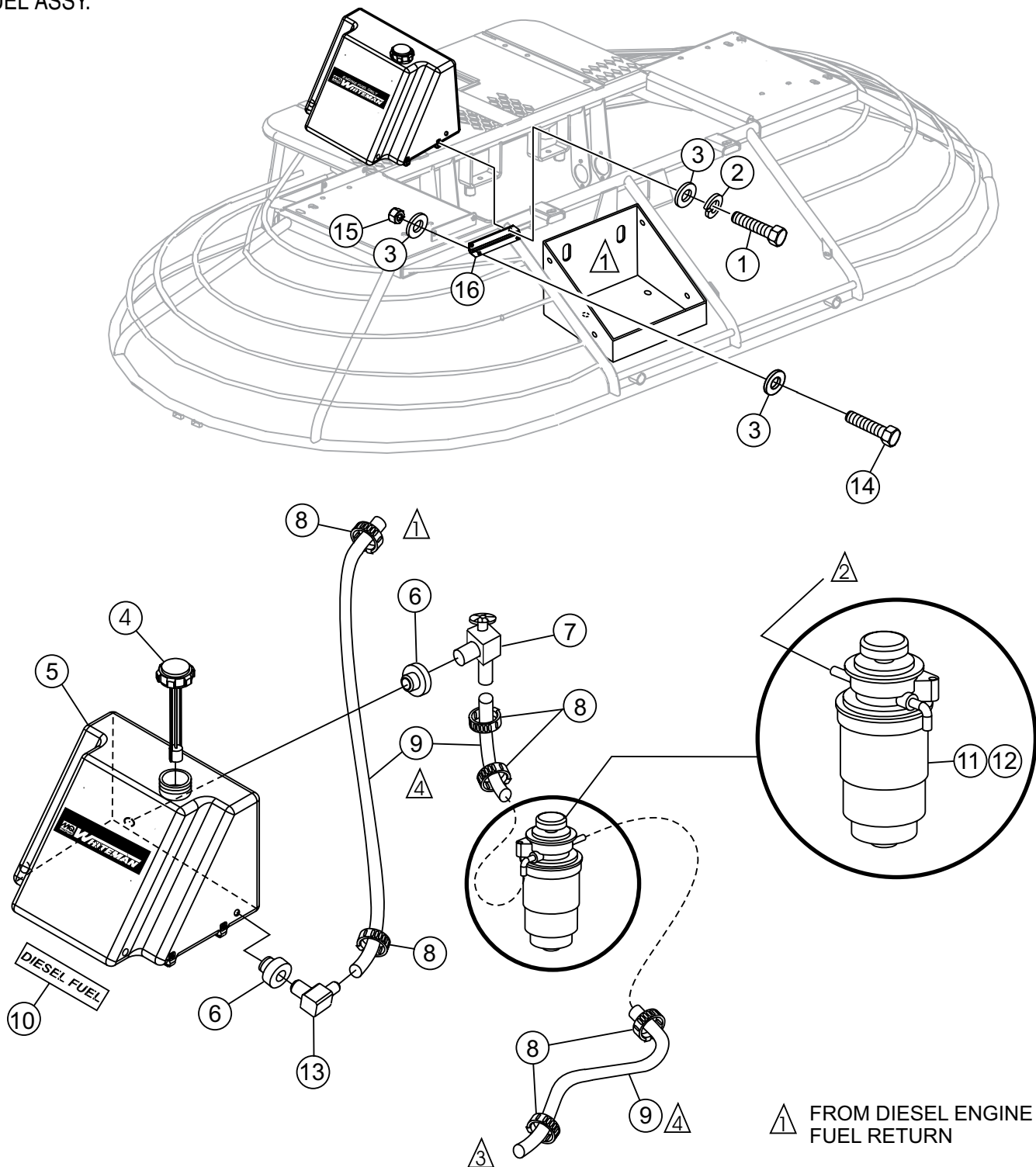

- ▲ FROM DIESEL ENGINE FUEL RETURN
- ▲ TO DIESEL ENGINE. (DIESEL FUEL FILTER/WATER SEPARATOR.)
- ▲ TO FUEL INJECTORS.
- ▲ CUT TO FIT.

FUEL ASSY.

<u>NO.</u>	<u>PART NO.</u>	<u>PART NAME</u>	<u>QTY.</u>	<u>REMARKS</u>
1	4514	SCREW, HHC 1/4-20 X 5/8.....	4.....	OLD STYLE COMET CLUTCH
1	1579	SCREW, HHC 1/4-20 X .5.....	4.....	NEW STYLE MULTI-CLUTCH
2	0161 C	WASHER, LOCK, 5/16 MED.....	4.....	OLD STYLE COMET CLUTCH
3	0948	WASHER, FLAT, 1/4 SAE .....	4.....	OLD STYLE COMET CLUTCH
3	0948	WASHER, FLAT 1/4 SAE.....	12.....	NEW STYLE MULTI-CLUTCH
4	11418	FUEL CAP/GAUGE (10.5")	1	
5	20292	TANK, FUEL DIESEL	1	
6	19633	BUSHING, RUBBER FUEL DAPCO10672	2	
7	20795	VALVE , SCREENED DAPCO 12570	1	
8	19473	CLAMP, WORM HOSE, #4 (1/4-5/8)	8	
9	60013	HOSE, .25 ID RUBBER FUEL LINE .....	6.....	SOLD IN FOOT LENGTHS
10	11811	DECAL, DIESEL FUEL	1	
11	825219	FUEL FILTER COMPLETE	1	
12	820311	FUEL FILTER ELEMENT ONLY	1	
13	12007	FITTING, 90 4BARB-4BARB FUEL	1	
14	0131 A	SCREW, HHC 1/4-20 X 3/4.....	4.....	NEW STYLE MULTI-CLUTCH
15	10024	NUT, NYLOC 1/4-20 .....	4.....	NEW STYLE MULTI-CLUTCH
16	22588	MOUNT, FUEL TANK .....	1.....	NEW STYLE MULTI-CLUTCH

# HHN 34TVD — DRIVE ASSY. (OLD STYLE)

## DRIVE ASSY. (OLD STYLE)

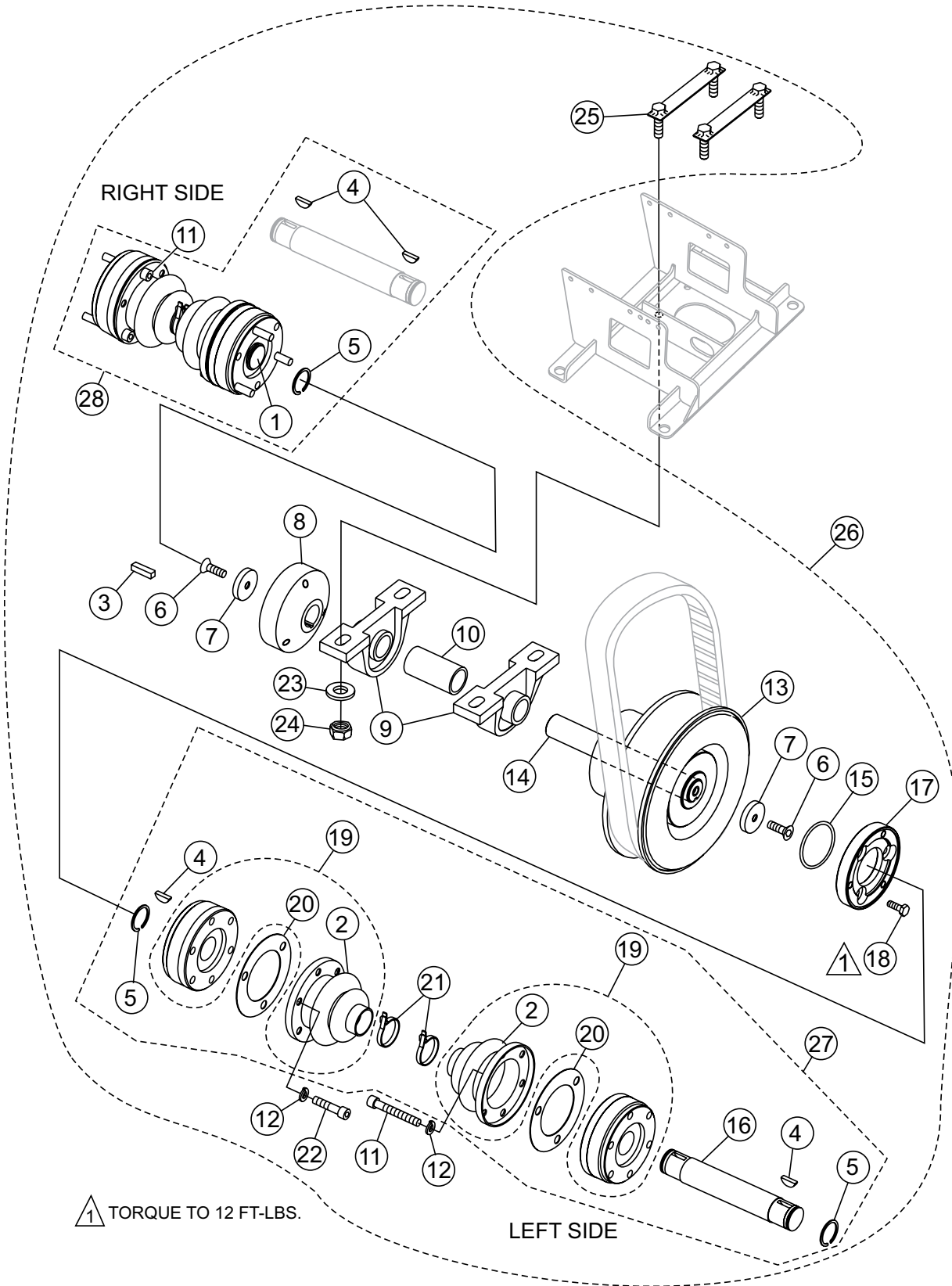

# HHN 34TVD — DRIVE ASSY. (OLD STYLE)

## DRIVE ASSY. (OLD STYLE)

<u>NO.</u>	<u>PART NO.</u>	<u>PART NAME</u>	<u>QTY.</u>	<u>REMARKS</u>
1 #@\$	2043	SHAFT, CV JOINT BRT, 9-5/8 LONG	1	
2%#@\$	2259	BOOT, C.V. JOINT	4	
3 #	10909	KEY, 3/16 X 11/16	1	
4 #@\$	0126	KEY, WOODRUFF #9	4	
5 #@\$	2090	RING, SNAP TRUARC #5100- 106	4	
6 #	1146	SCREW, FHSC 5/16- 18 X 1 NYLOC	2	
7 #	2037	WASHER, RETAINING	2	
8 #	2029	COUPLER, 1 ID. RIDER	1	
9 #	10337	BEARING, PILLOW BLOCK FAF YAK- 1	2	
10 #	20044	SPACER, BEARING SHAFT	1	
11 #	2186	SCREW, SHC 5/16-18 X 2-1/4 PLTD	9	
12 #	0161 C	WASHER, LOCK, 5/16 MEDIUM	12	
13 #	21475	PULLEY, CVT LOWER	1	
14 #	20043	SHAFT, DRIVE BEARING	1	
15 #	20116	O-RING, SIZE- 031 BUNA N	1	
16 #	20184	SHAFT, CV JOINT, HHN 7-13/16 LONG	1	
17 #	12590	COUPLER, CV JOINT COMET CLUTCH	1	
18 #	20056	SCREW, HHC 1/4- 28 X 3/4 GRD. 8	3	
19 #@\$	2052	JOINT, CV W/BOOT.....	4	INCLUDES ITEM W/%
20 #@\$	11108	GASKET, CV JOINT BOOT	4	
21 #@\$	1662	TIE, CABLE TY-RAP	4	
22 #	0243	SCREW, SHC 5/16- 18 X 1-3/4	3	
23 #	10136	WASHER, FLAT 3/8 SAE	4	
24 #	10133	NUT, NYLOC 3/8 - 16	4	
25 #	20186	PLATE, BEARING MOUNT	2	
26	21493	DRIVE ASSY., W/ COMET 34V TD.....	1	INCLUDES ITEMS W/#
27#	23450	CV JOINT ASSY, RH .....	1	INCLUDES ITEMS W/@
28#	23451	CV JOINT ASSY, LH.....	1	INCLUDES ITEMS W/\$



MULTI-CLUTCH COMPONENTS ARE NOT INTERCHANGEABLE WITH THE PRIOR HOFFCO COMET DRIVE SYSTEM. THE HOFFCO COMET CVT SYSTEM MUST BE REPLACED FOR COMPATIBILITY WITH THE NEW EQUIPMENT.

# HHN 34TVD — DRIVE ASSY. (NEW STYLE)

## DRIVE ASSY. (NEW STYLE)

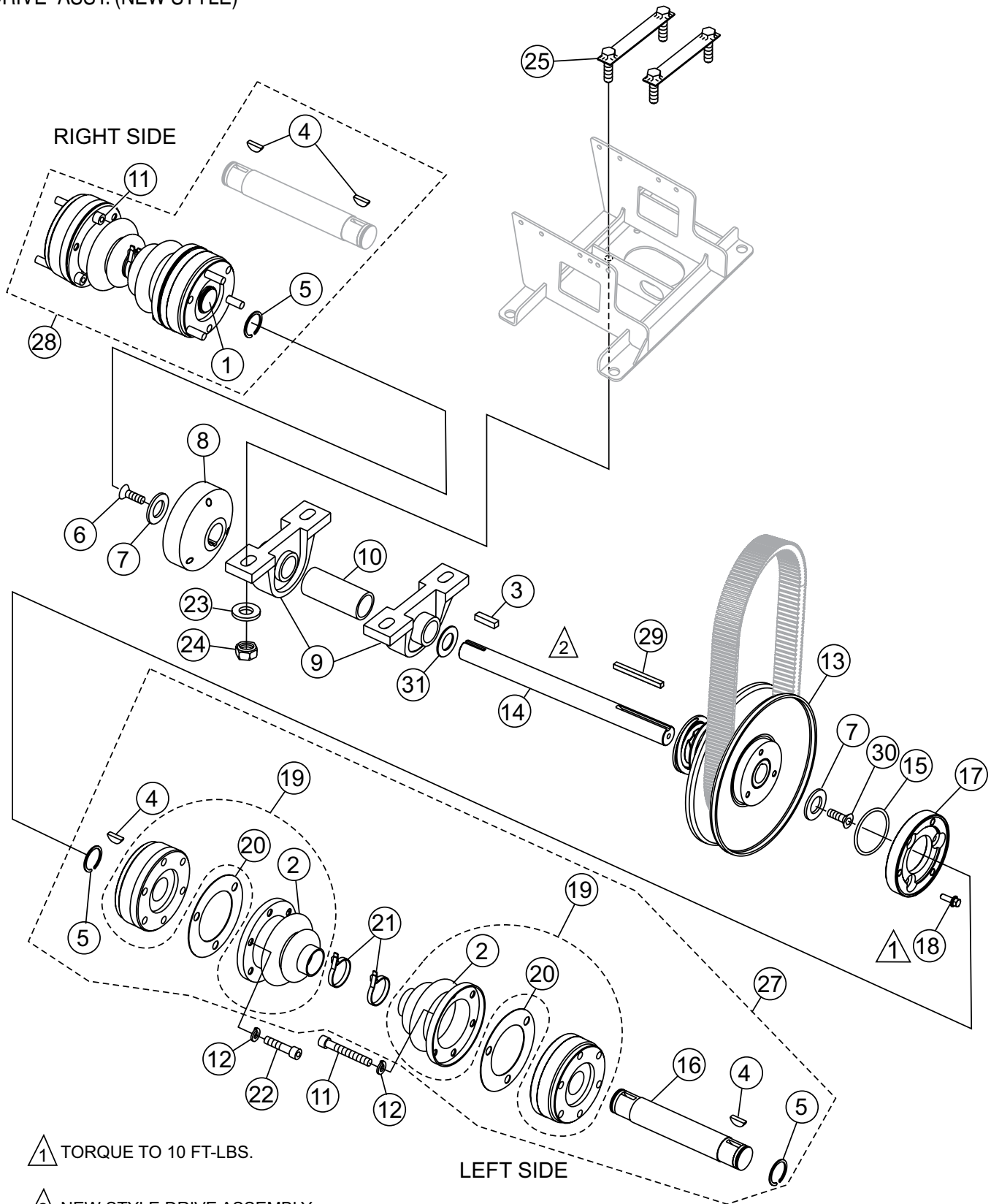

# HHN 34TVD — DRIVE ASSY. (NEW STYLE)

## DRIVE ASSY. (NEW STYLE)

<u>NO.</u>	<u>PART NO.</u>	<u>PART NAME</u>	<u>QTY.</u>	<u>REMARKS</u>
1 @\$	2043	SHAFT, CV JOINT BRT, 9-5/8 LONG	1	
2%@\$	2259	BOOT, C.V. JOINT	4	
3	10909	KEY, 3/16 X 11/16	1	
4 @\$	0126	KEY, WOODRUFF #9	4	
5 @\$	2090	RING, SNAP TRUARC #5100- 106	4	
6	1146	SCREW, FHSC 5/16- 18 X 1 NYLOC	1	
7	2037	WASHER, RETAINING	2	
8	2029	COUPLER, 1 ID. RIDER	1	
9	10337	BEARING, PILLOW BLOCK FAF YAK- 1	2	
10	23431	SPACER, 1.25DIA X 1.01ID X 4.81	1	
11	2186	SCREW, SHC 5/16-18 X 2-1/4 PLTD	9	
12	0161 C	WASHER, LOCK, 5/16 MEDIUM	12	
13	23363-2	PULLEY, CVT DRIVEN LOWER	1	
14	23430	SHAFT, DRIVE BEARING 1.00 x 12.5	1	
15	20116	O-RING, SIZE- 031 BUNA N	1	
16	20184	SHAFT, CV JOINT, HHN 7-13/16 LONG	1	
17	23433	COUPLER, CV JOINT CCVT	1	
18	9165	SCREW, HHFS 1/4-28 X 3/4 GR5 PATCH	3	
19 @\$	2052	JOINT, CV W/BOOT .....	4	INCLUDES ITEM W/%
20 @\$	11108	GASKET, CV JOINT BOOT	4	
21 @\$	1662	TIE, CABLE TY-RAP	4	
22	0243	SCREW, SHC 5/16- 18 X 1-3/4	3	
23	10136	WASHER, FLAT 3/8 SAE	4	
24	10133	NUT, NYLOC 3/8 - 16	4	
25	20186	PLATE, BEARING MOUNT	2	
27	23450	CV JOINT ASSY, RH .....	1	INCLUDES ITEMS W/@
28	23451	CV JOINT ASSY, LH .....	1	INCLUDES ITEMS W/\$
29	20363	KEY, REC .188 X .25 X 2.5	1	
30	9092	SCREW, FHSC 5/8-18X1.25 NYLON	1	
31	11773	SHIM, .031"	A/R	

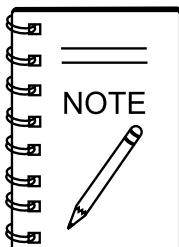

MULTI-CLUTCH COMPONENTS ARE NOT INTERCHANGEABLE WITH THE PRIOR HOFFCO COMET DRIVE SYSTEM. THE HOFFCO COMET CVT SYSTEM MUST BE REPLACED FOR COMPATIBILITY WITH THE NEW EQUIPMENT.

# HHN 34TVD — 5-BLADE SPIDER ASSY. (LEFT)

## 5-BLADE SPIDER ASSY. (LEFT)

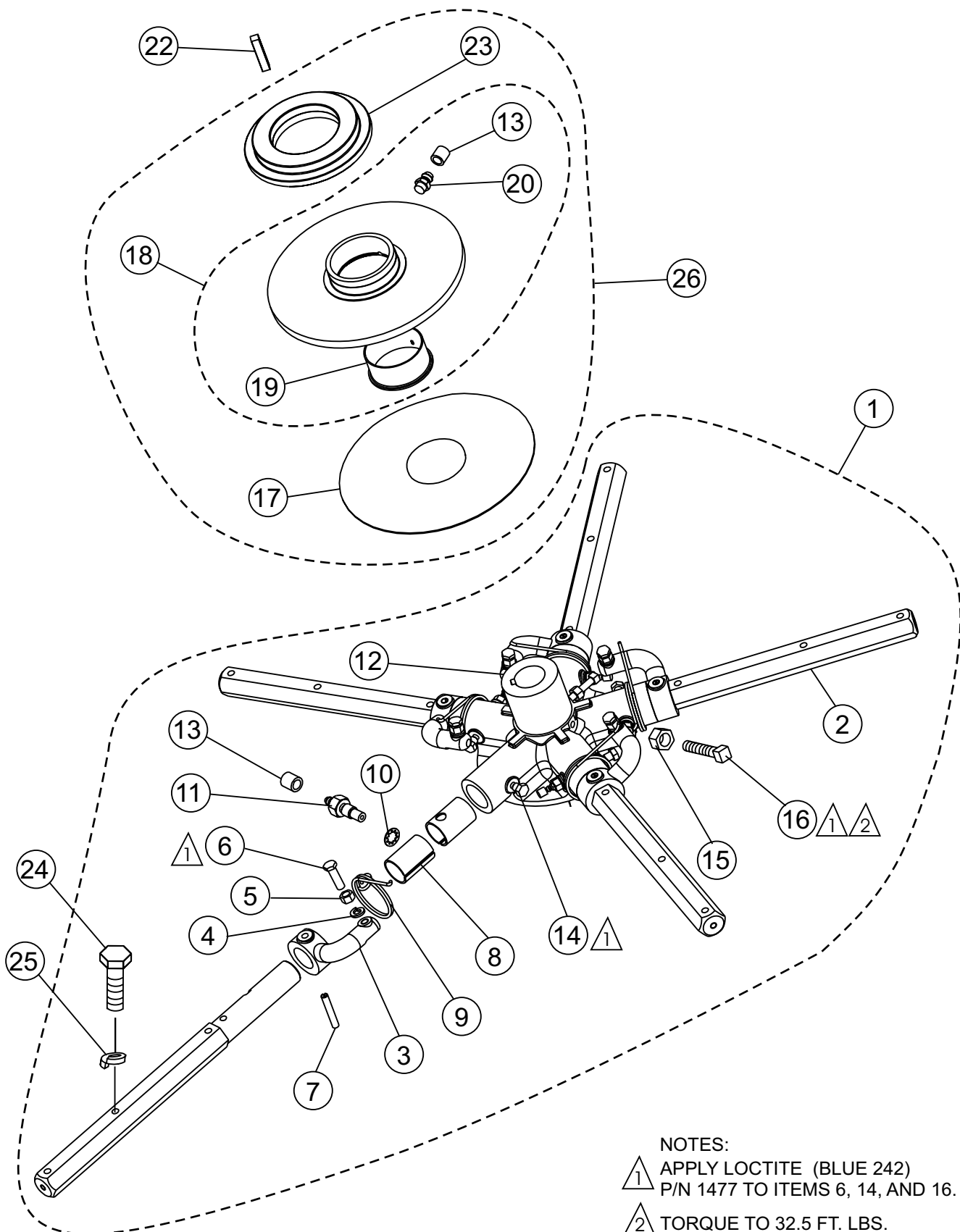

### NOTES:

- 1 APPLY LOCTITE (BLUE 242)  
P/N 1477 TO ITEMS 6, 14, AND 16.
- 2 TORQUE TO 32.5 FT. LBS.

# HHN 34TVD — 5-BLADE SPIDER ASSY. (LEFT)

## 5-BLADE SPIDER ASSY. (LEFT)

<u>NO.</u>	<u>PART NO.</u>	<u>PART NAME</u>	<u>QTY.</u>	<u>REMARKS</u>
1	12932	SPIDER ASSY., LEFT SIDE (1-1/2).....	1	INCLUDES ITEMS W/#
2#	2829	ARM, TROWEL EXTENDED	5	
3#	11903	LEVER, TROWEL ARM LEFT SIDE	5	
4#	0166 A	WASHER, LOCK, 3/8 MED	5	
5#	1876	NUT, HEX JAM 3/8	5	
6#	0164 B	SCREW, HHC	5	
7#	9006	PIN, ROLL 5/16 X 2	5	
8#	11039	BUSHING, 1/2 HD TROWEL ARM .....	10	REQUIRES 2 BUSHINGS PER ARM
9#	9111	SPRING, LEFT TROWEL	5	
10#	1875	WASHER, INT SHKP 3/8	5	
11#	1322	SCREW ASSY., ARM RETAINING	5	
12#	21208	PLATE, SPIDER 5 BLADE (1-1/2 SHAFT) .....	1	INCLUDES ITEMS W/%
13@#	1162 A	CAP, GREASE ZERK #2	6	
14@%	11602	SCREW, HHS 3/8-16 X 1/4	5	
15#	1456	NUT, HEX FINISH 3/8 -16	2	
16#	12097	SCREW, SQHS 3/8-16 X 1-3/4 CONE 8	2	
17@	11419	PLATE, WEAR	1	
18@	11431	THRUST COLLAR .....	1	INCLUDES ITEM W/+
19@+	20426	BUSHING, THRUST COLLAR	1	
20@	2621	FITTING, GREASE	1	
22	12687	KEY, 3/8 X 2	1	
23@	12779	BEARING, THRUST 6017 2RS W/FLANGE	1	
24	0105	SCREW, HHC 5/16-18 X 1-1/2"	15	
25	0161 C	Lock Washer 5/16"	15	
26	20938	THRUST COLLAR ASSY. ....	1	INCLUDES ITEMS W/@

# HHN 34TVD — 5-BLADE SPIDER ASSY. (RIGHT)

## 5-BLADE SPIDER ASSY. (RIGHT)

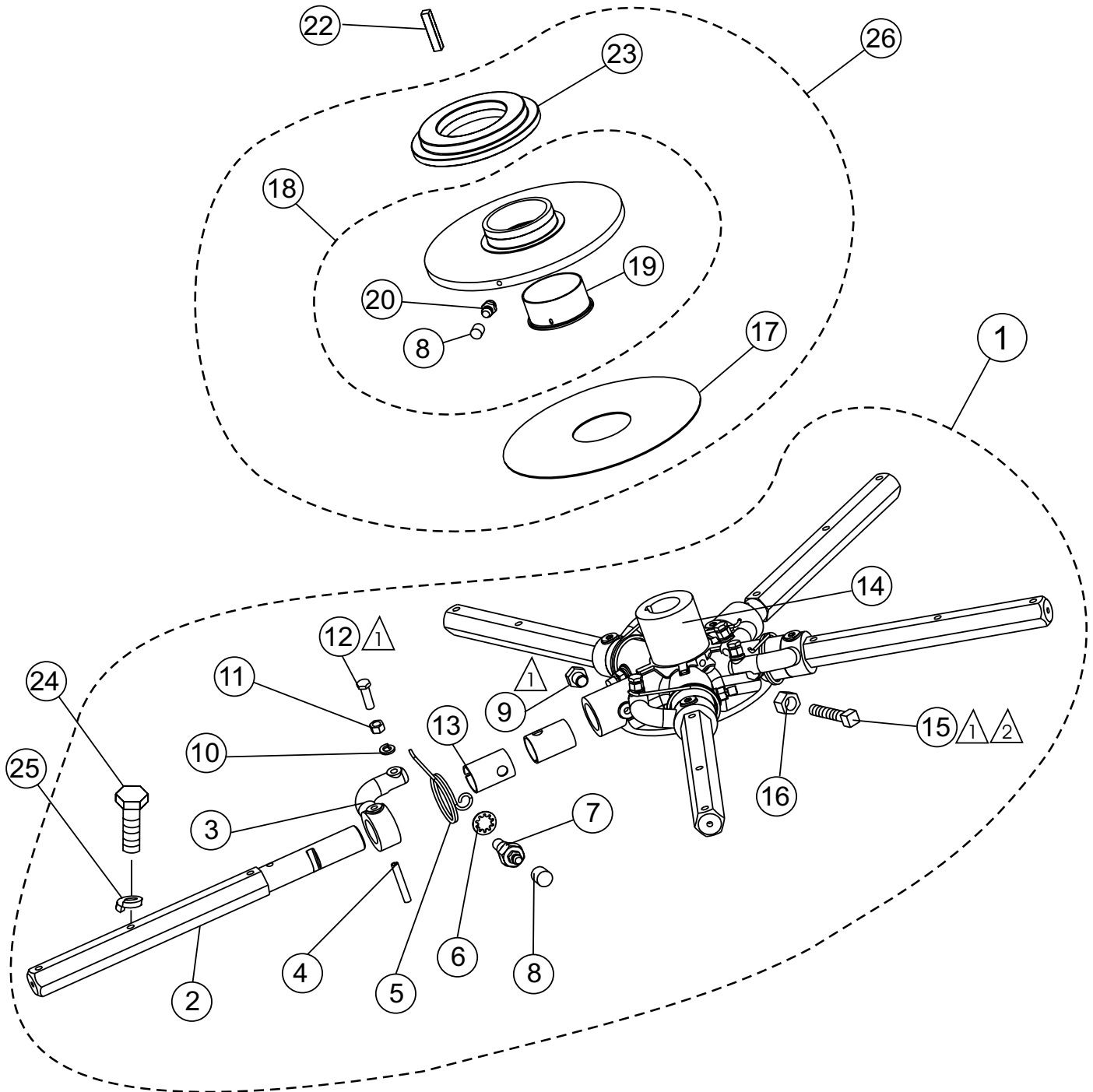

NOTES:

① APPLY LOCTITE (BLUE 242)  
P/N 1477 TO ITEMS 9, 12, AND 15.

② TORQUE TO 32.5 FT. LBS.

# HHN 34TVD — 5-BLADE SPIDER ASSY. (RIGHT)

## 5-BLADE SPIDER ASSY. (RIGHT)

<u>NO.</u>	<u>PART NO.</u>	<u>PART NAME</u>	<u>QTY.</u>	<u>REMARKS</u>
1	12933	SPIDER ASSY., RIGHT SIDE (1-1/2) .....	1.....	INCLUDES ITEMS W/#
2#	2829	ARM, TROWEL EXTENDED	5	
3#	11904	LEVER, TROWEL ARM RIGHT SIDE	5	
4#	9006	PIN, ROLL 5/16 X 2	5	
5#	2143	SPRING, RIGHT TROWEL	5	
6#	1875	WASHER, INT SHKP 3/8	5	
7#	1322	SCREW ASSY., ARM RETAINING	5	
8@#	1162 A	CAP, GREASE ZERK #2	6	
9 #%	11602	SCREW, SHS 3/8-16 X 1/4	5	
10#	0166 A	WASHER, LOCK, 3/8 MED	5	
11#	1876	NUT, HEX JAM 3/8	5	
12#	0164 B	SCREW, HHC	5	
13#	11039	BUSHING, 1/2 HD TROWEL ARM .....	10 .....	REQUIRES 2 BUSHINGS PER ARM
14#	21208	PLATE, SPIDER 5 BLADE (1-1/2 SHAFT) .....	1.....	INCLUDES ITEMS W/%
15#	12097	SCREW, SQHS 3/8-16 X 1-3/4 CONE 8	2	
16#	1456	NUT, HEX FINISH 3/8 -16	2	
17@	11419	PLATE, WEAR	1	
18@	11431	THRUST COLLAR .....	1.....	INCLUDES ITEM W/+
19@+	20426	BUSHING, THRUST COLLAR	1	
20@	2621	FITTING, GREASE	1	
22	12687	KEY, 3/8 X 2	1	
23@	12779	BEARING, THRUST 6017 2RS W/FLANGE	1	
24	0105	SCREW, HHCS 5/16-18 X 1-1/2"	15	
25	0161 C	Lock Washer 5/16"	15	
26	20938	THRUST COLLAR ASSY. ....	1.....	INCLUDES ITEMS W/@

# HHN 34TVD — STABILIZER RING ASSY.

STABILIZER ASSY.

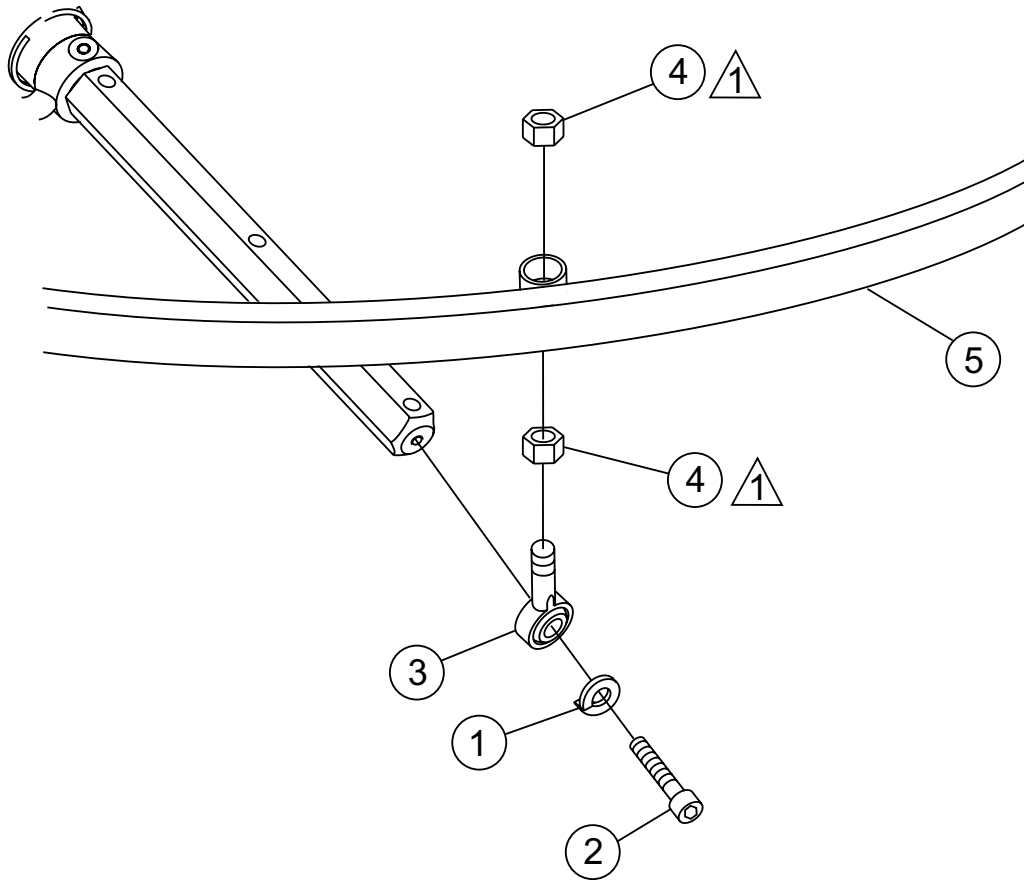

 APPLY LOCTITE 242 BLUE OR EQUIVALENT.

## HHN 34TVD — STABILIZER RING ASSY.

### STABILIZER ASSY.

<u>NO.</u>	<u>PART NO.</u>	<u>PART NAME</u>	<u>QTY.</u>	<u>REMARKS</u>
1	0161 C	LOCK WASHER 5/16"	5	
2	1237	SCREW, SHC 5/16-18 X 7/8	5	
3	1723	ROD END, 5/16-24 MALE	5	
4	6014 C	NUT, HEX FINISH 5/16-24	10	
5	12095	RING, STAB, 5 BLADE	1	

NOTE: INDICATED QUANTITIES ARE FOR ONE SIDE ONLY.  
IF ORDERING FOR BOTH SIDES DOUBLE QUANTITY.

# HHN 34TVD — SEAT AND FRAME ASSY.

## SEAT AND FRAME ASSY.

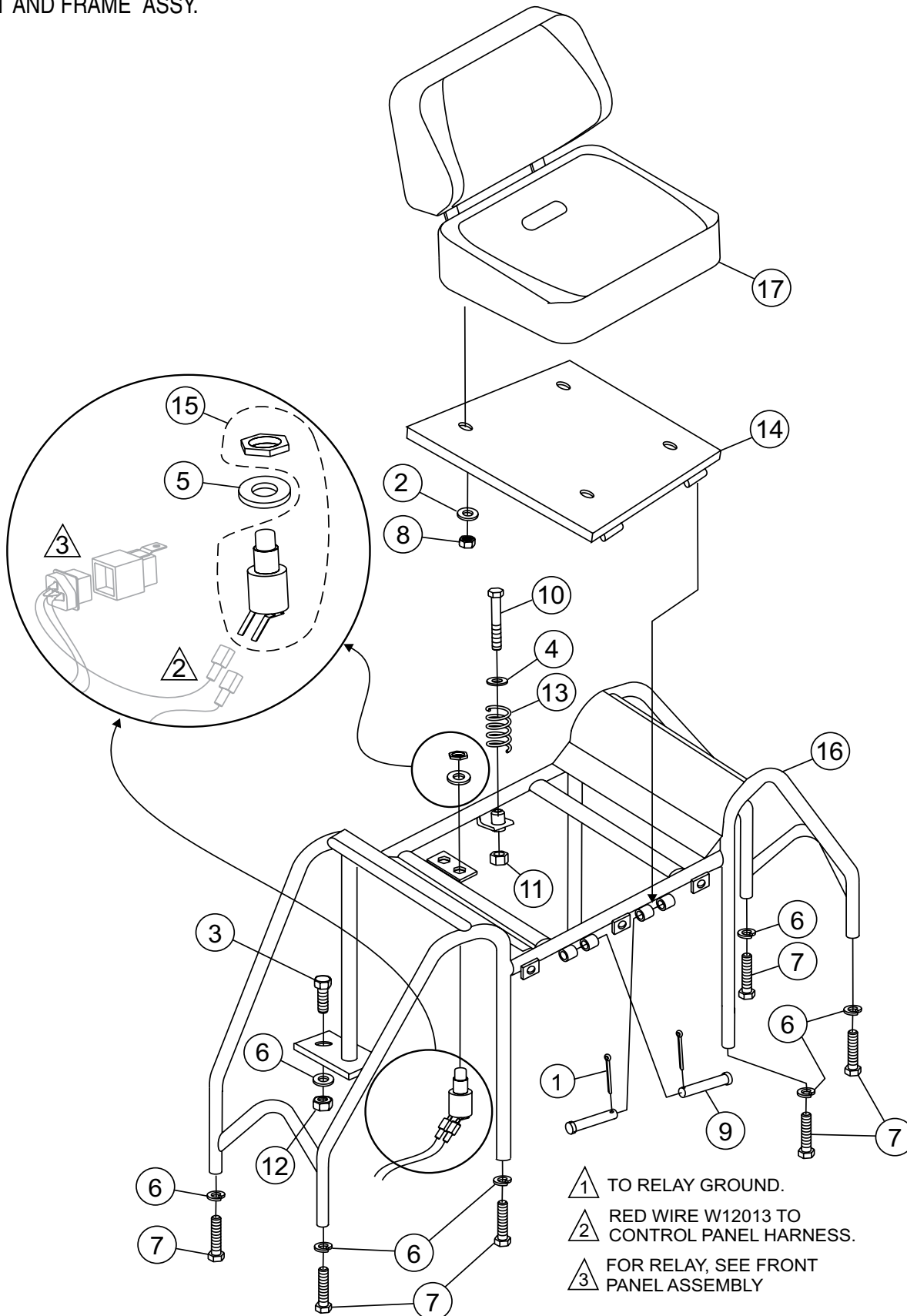

# HHN 34TVD — SEAT AND FRAME ASSY.

## SEAT AND FRAME ASSY.

<u>NO.</u>	<u>PART NO.</u>	<u>PART NAME</u>	<u>QTY.</u>	<u>REMARKS</u>
1	0183	PIN, COTTER 1/8 X1-1/4	2	
2	0300 B	WASHER, FLAT, 5/16 SAE	4	
3	3214	SCREW, HHC 1/2 - 13 X 1-1/4	2	
4	4001	WASHER, FLAT, 3/8 USS PLD	1	
5	4684	WASHER, FLAT SAE 5/8 PLTD	1	
6	5054 A	WASHER, LOCK, 1/2 MED.	8	
7	5218	SCREW, HHC 1/2-13X1 1/2	6	
8	5283	NUT, NYLOC 5/16-18	4	
9	8081	PIN, CLEVIS 1/2X2 3/4	2	
10	8156	SCREW, HHC 3/8-16 X 2-1/2	1	
11	10133	NUT, NYLOC 3/8-16	1	
12	10176	NUT, NYLOC 1/2-13	2	
13	11593	SPRING, SEAT	1	
14	11660	PLATE, SEAT W/A HHN	1	
15	12005	SWITCH, SAFETY STOP .....	1.....	SAFETY ITEM
16	12987	FRAME, SEAT	1	
17	20989	SEAT, ADJUSTABLE	1	

# HHN 34TVD — FRAME AND COMPONENTS ASSY.

## FRAME AND COMPONENTS ASSY.

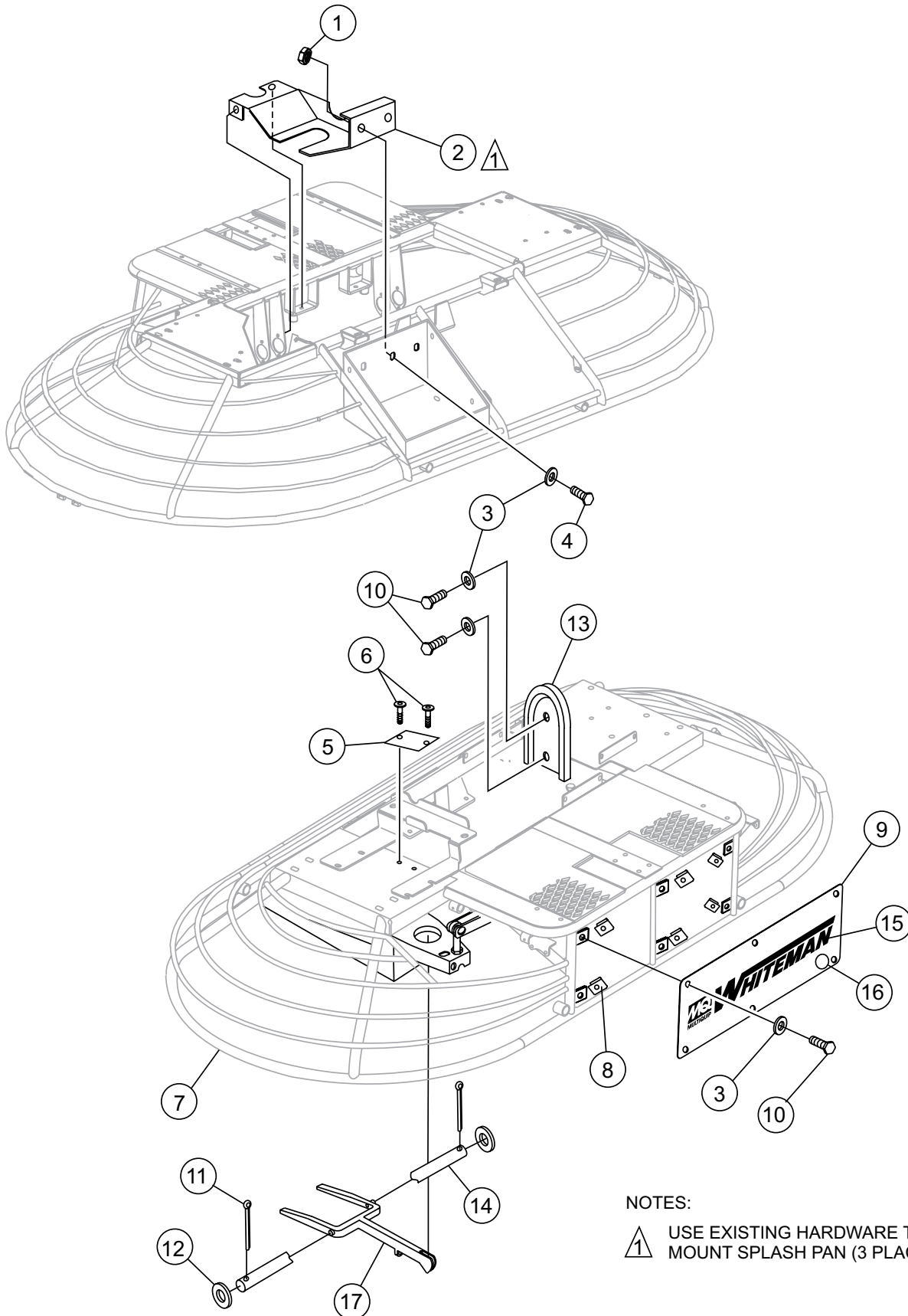

# HHN 34TVD — FRAME AND COMPONENTS ASSY.

## FRAME AND COMPONENTS ASSY.

<u>NO.</u>	<u>PART NO.</u>	<u>PART NAME</u>	<u>QTY.</u>	<u>REMARKS</u>
1	10024	NUT, NYLOC 1/4 - 20	1	
2	20957	PAN, SPLASH	1	
3	0948	WASHER, FLAT, 1/4 SAE	9	
4	0730	SCREW, HHC 1/4 - 20 X 1	1	
5		PLATE, SERIAL, RIDER .....	1	.....CONTACT MQ PARTS DEPT.
6	4014	SCREW, 2-3/16 P-K TYPE U DRIVE	2	
7	12896	FRAME , COMPLETE HHN	1	
8	11534	NUT "U" TYPE, 1/4-20	6	
9	20946	PANEL, FRONT BODY	1	
10	4514	SCREW, HHC 1/4-20X5/8	8	
11	0183	PIN COTTER 3/32X3/4	4	
12	0448	WASHER, FLAT, 7/16 SAE	4	
13	2429	HOLDER, SPARE BELT ALL	1	
14	11648	SHAFT, YOKE PIVOT	2	
15	10818	DECAL, MQ WHITEMAN, 24 X 3	1	
16	13118	DECAL, "POWDER COATED"	1	
17	11499	YOKE ARM	2	

# HHN 34TVD — FOOT PEDALS ASSY.

## FOOT PEDALS ASSY.

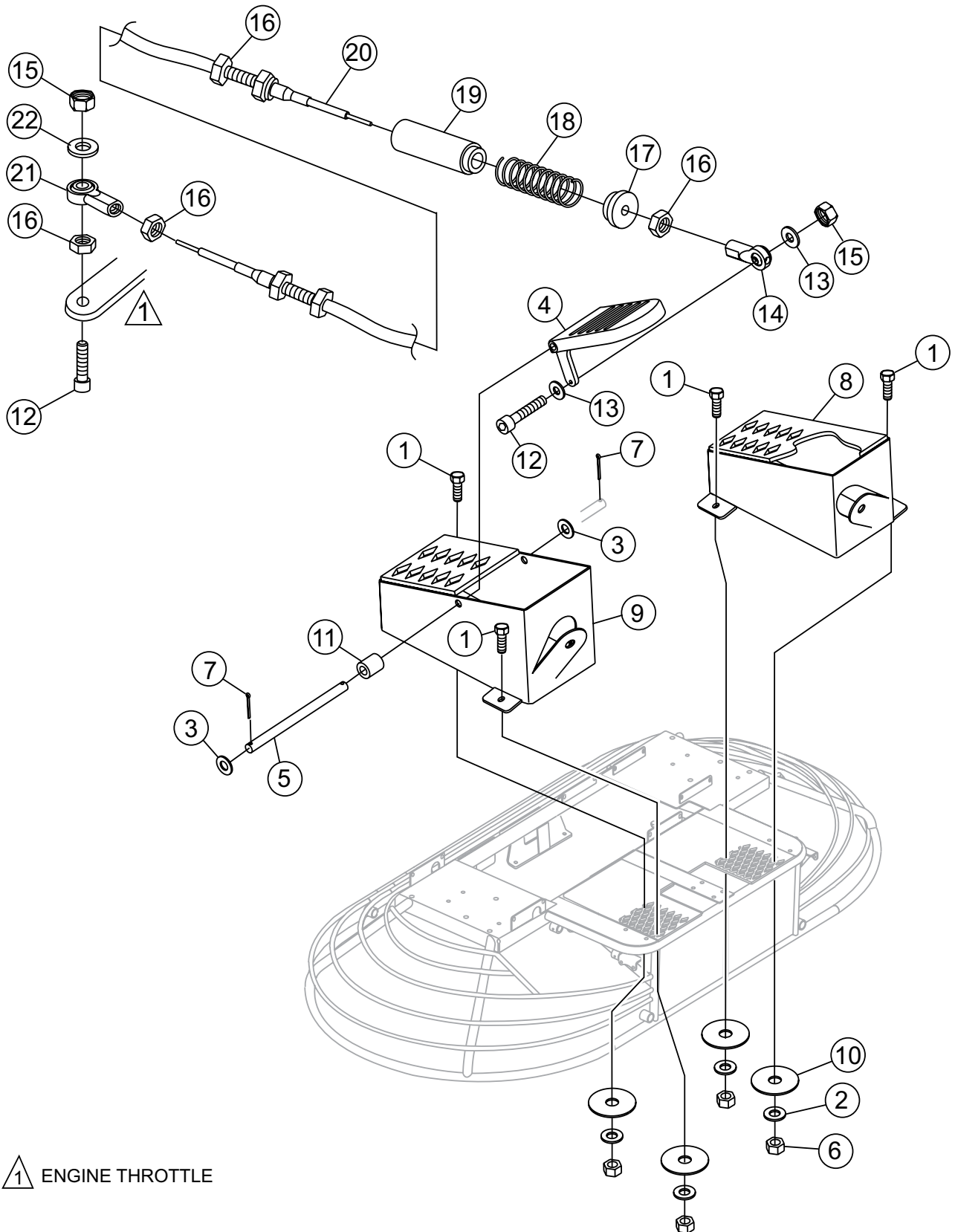

## HHN 34TVD — FOOT PEDALS ASSY.

### FOOT PEDALS ASSY.

<u>NO.</u>	<u>PART NO.</u>	<u>PART NAME</u>	<u>QTY.</u>	<u>REMARKS</u>
1	0202	SCREW, HHC 5/16 - 18 X 1	4	
2	0300 B	WASHER, FLAT, 5/16 SAE	4	
3	10136	WASHER, FLAT, 3/8 SAE	2	
4	2086	PEDAL, ACCELERATOR	1	
5	2772	PIN, ACC MOUNT	1	
6	5283	NUT, NYLOC 5/16 - 18	4	
7	6014 B	PIN, COTTER 3/32 X 1	2	
8	12985	LEFT SIDE FOOT REST	1	
9	12986	RIGHT SIDE FOOT REST	1	
10	3233	WASHER, FENDER, 1.50D X 3/8ID	4	
11	3083	SPACER	1	
12	10018	SCREW, SHC 10-32 X 1 NO PLATE	2	
13	2203	WASHER, FLAT #10	2	
14	2153	ROD END, 10-32 FEMALE RH	2	
15	10019	NUT, NYLOC 10-32	2	
16	0937	NUT, HEX 10-32	3	
17	2755	ADAPTER, THROTTLE RET. SPRING SHORT	1	
18	2753	SPRING, THROTTLE RETURN, LOWER	1	
19	2754	ADAPTER, THROTTLE RET. SPRING LARGE	1	
20	2124	CABLE, THROTTLE (RT)	1	
21	2153	ROD END, 10-32 FEMALE RH	1	
22	0948	WASHER, FLAT 1/4 SAE	1	

# HHN 34TVD — BATTERY ASSY.

## BATTERY ASSY.

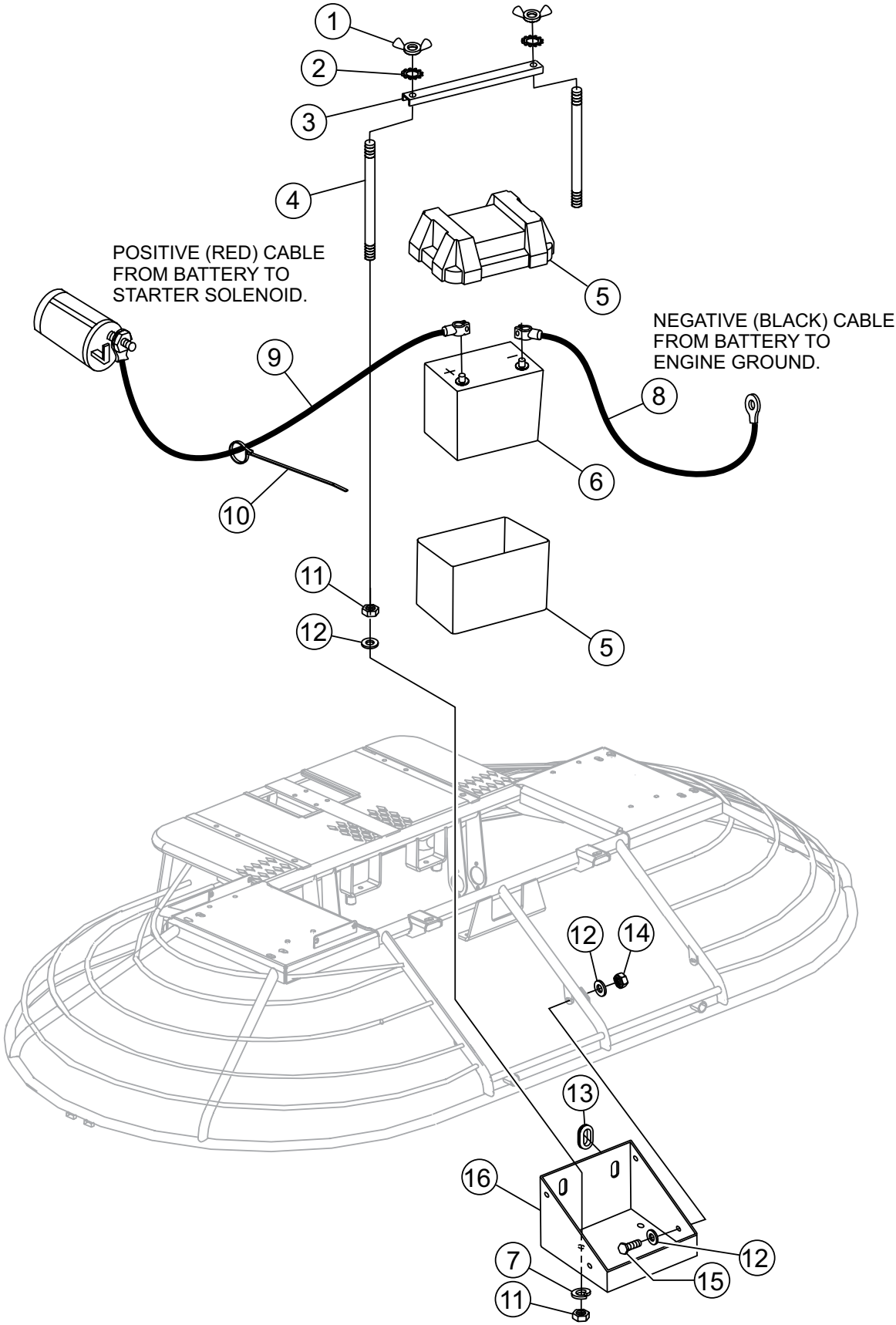

## BATTERY ASSY.

<u>NO.</u>	<u>PART NO.</u>	<u>PART NAME</u>	<u>QTY.</u>	<u>REMARKS</u>
1	2509	NUT, WING 1/4-20 PLATED	2	
2	10031	WASHER, EXT SHKP, 1/4	2	
3	11692	BRACKET, BATTERY BOX HOLD DOWN	1	
4	11693	BOLT, BATTERY BRKT	2	
5	10318	BATTERY BOX, GROUP 24, W/LID	1	
6		BATTERY, 12V WET GROUP 22 .....	1.....	USE INTERSTATE BATTERY P/N 22F-60
7	0181 B	WASHER, LOCK 1/4 MEDIUM	6	
8	10313	CABLE, NEG BATTERY BLACK 20"	1	
9	19303	CABLE, POS BATTERY RED 48"	1	
10	1662	TIE, CABLE TY-RAP BLACK.....	6.....	AS REQUIRED
11	0949	NUT, HEX FINISH 1/4-20	4	
12	0948	WASHER, FLAT, 1/4SAE	8	
13	13212	GROMMET, 1 - 1/4 ID	1	
14	10024	NUT, NYLOC 1/4-20	4	
15	0730	SCREW, HHC 1/4-20X1	4	
16	11362	BATTERY FRAME BOX	1	

# HHN 34TVD — SPRAY ASSY.

## SPRAY ASSY.

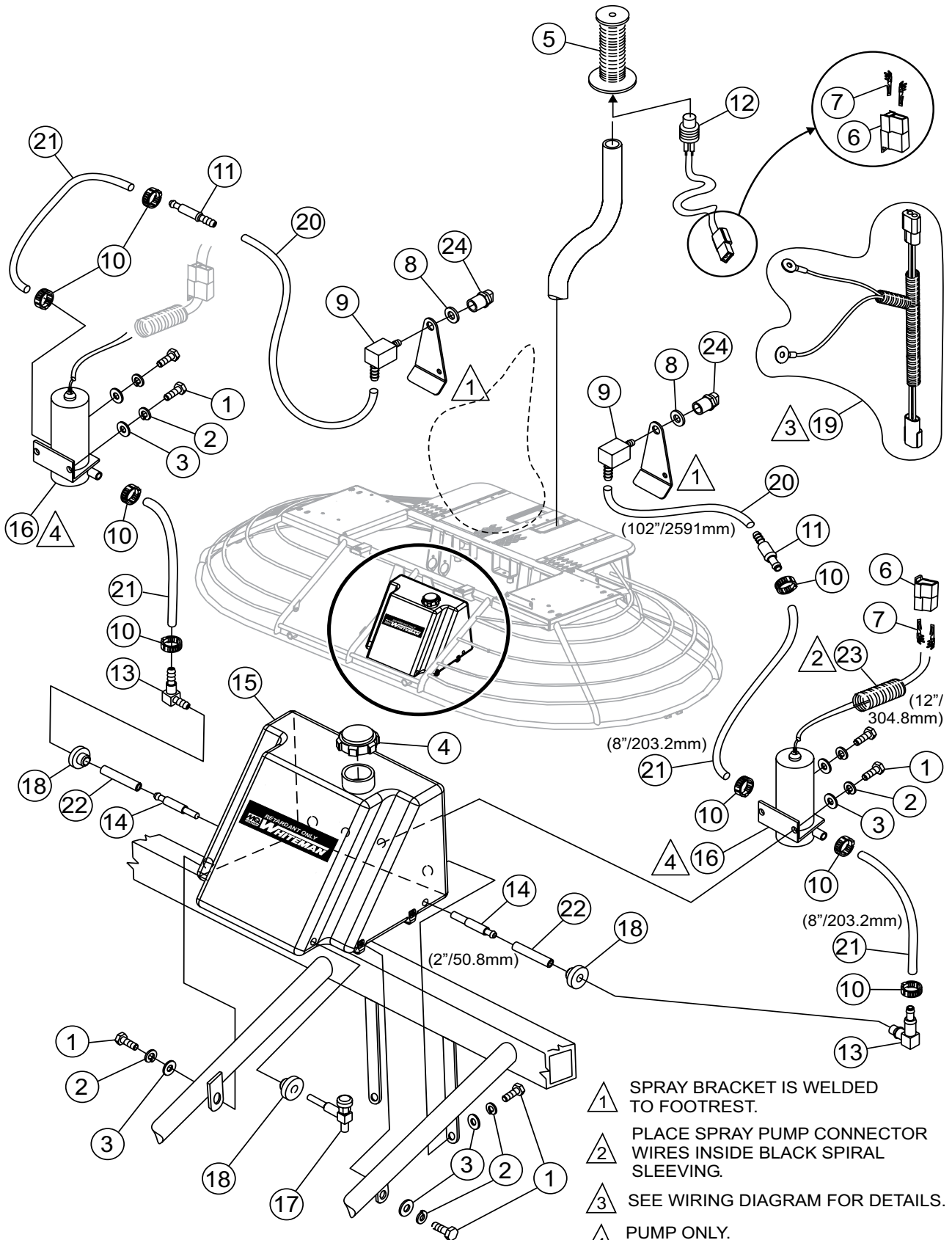

SPRAY ASSY.

<u>NO.</u>	<u>PART NO.</u>	<u>PART NAME</u>	<u>QTY.</u>	<u>REMARKS</u>
1	0131 A	SCREW, HHC 1/4-20 X 3/4	6	
2	0181 B	WASHER, LOCK, 1/4 MED	6	
3	0948	WASHER, FLAT, 1/4 SAE	6	
4	2108	CAP, SPRAY TANK	1	
5	2267	GRIP, HANDLE RT	2	
6	2680	CONNECTOR, 2-WIRE FEMALE	3	
7	2687	TERMINAL, MALE 16-19 GA	6	
8	2898	WASHER, BONDED NEOPRENE 1 X 1/2	2	
9	2912	FITTING, 90 4 BARB -1/4 FP	2	
10	2918	CLAMP, HOSE, 475 - 536 ID	8	
11	10022	FITTING, PLASTIC 6 BARB - 4 BARB	2	
12	11430	SWITCH ASSY., HTO/HTH SPRAY	2	
13	12008	FITTING, 90 6 BARB - 4 BARB FUEL	2	
14	12009	SCREEN, FILTER	2	
15	12403	TANK, RETARDANT 5 GALLON	1	
16	12548	PUMP, SPRAY	2	
17	19661	VALVE, FUEL DRAIN	1	
18	19633	BUSHING, RUBBER FUEL	3	
19	20094	HARNES, SPRAY PUMP	1	
20	60001	HOSE, .25 ID X .375 OD CLEAR PVC .....	9	SOLD IN FOOT LENGTHS
21	60002	HOSE, .375 ID X .5 OD TYGON .....	9	SOLD IN FOOT LENGTHS
22	60058	HOSE, 1/4 X 3/8 PVC FUEL YELLOW 6" LONG ....	1	SOLD IN FOOT LENGTHS
23	60221	LOOM, .375	1	
24	392292	NOZZLE, SPRAY	1	

LIGHT ASSY.

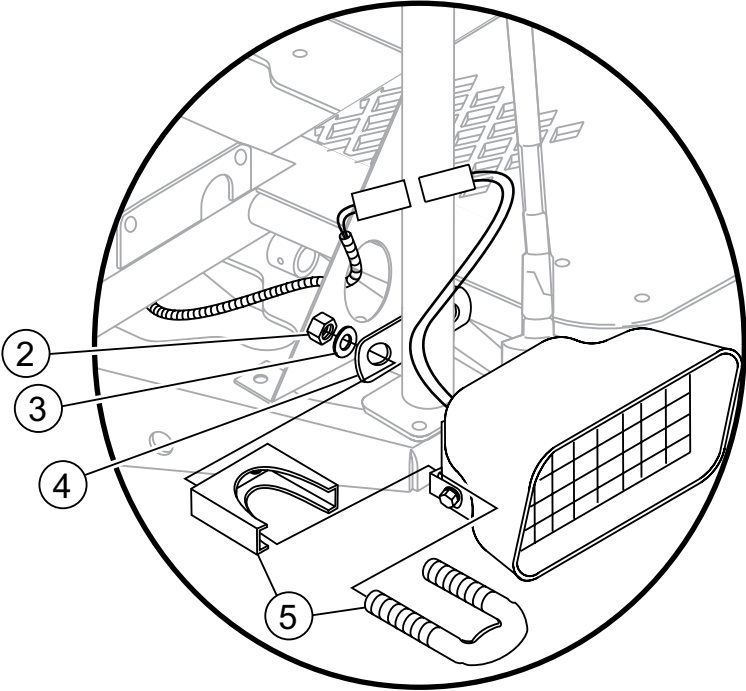
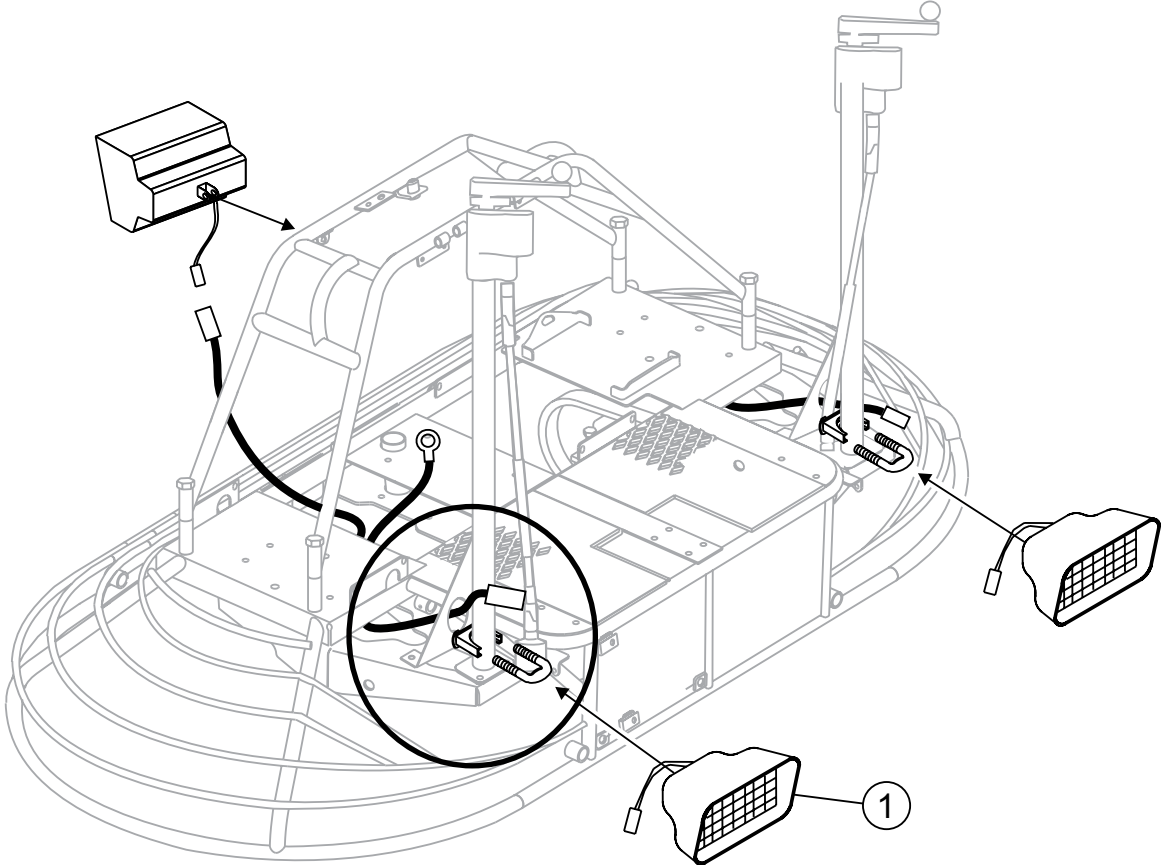

## LIGHTS ASSY.

<u>NO.</u>	<u>PART NO.</u>	<u>PART NAME</u>	<u>QTY.</u>	<u>REMARKS</u>
1	2896	LIGHT KIT ASSEMBLY .....	3.....	SAFETY ITEM
2	5283	NUT, NYLOC 5/16-18	4	
3	0300 B	WASHER, FLAT 5/16 SAE	4	
4	2531	BRACKET, LIGHT SIDE	2	
5	2534	CLAMP ASSY., MUFFLER 1-3/4	2	

# HHN 34TVD — FRONT PANEL ASSY.

## FRONT PANEL ASSY.

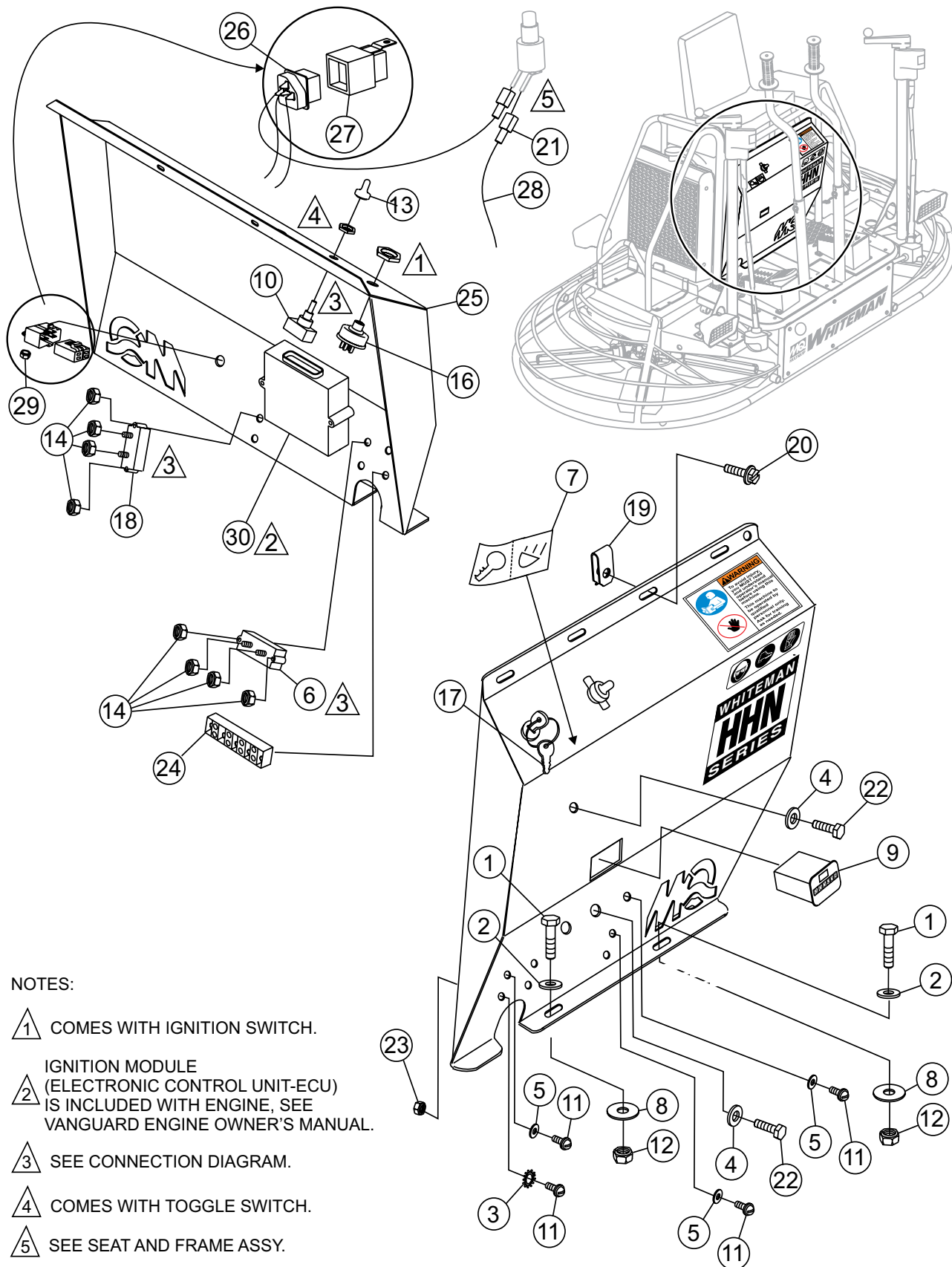

NOTES:

- ① COMES WITH IGNITION SWITCH.
- ② IGNITION MODULE (ELECTRONIC CONTROL UNIT-ECU) IS INCLUDED WITH ENGINE, SEE VANGUARD ENGINE OWNER'S MANUAL.
- ③ SEE CONNECTION DIAGRAM.
- ④ COMES WITH TOGGLE SWITCH.
- ⑤ SEE SEAT AND FRAME ASSY.

# HHN 34TVD — FRONT PANEL ASSY.

## FRONT PANEL ASSY.

<u>NO.</u>	<u>PART NO.</u>	<u>PART NAME</u>	<u>QTY.</u>	<u>REMARKS</u>
1	0202	SCREW, HHC 5/16-18 X 1	2	
2	0300 B	WASHER, FLAT, 5/16 SAE	2	
3	0479	WASHER, EXT. SHKP, #8 3/8 PLTD	2	
4	0948	FLAT WASHER 1/4 "	4	
5	2203	WASHER, FLAT, #10	4	
6	2673	CIRCUIT BREAKER, 30A, 12V	1	
7	2814	DECAL, CONTROL PANEL	1	
8	3233	WASHER, FENDER, 1.5 OD X 3/8 ID	2	
9	11694	HOUR METER .....	1	PART OF WIRE HARNESS #21514
10	4682	SWITCH, TOGGLE	1	
11	5065 B	SCREW, RHM 10-32 X 1/2	6	
12	5283	NUT, NYLOC 5/16-18	2	
13	8381	BOOT, TOGGLE SWITCH	1	
14	10019	NUT, NYLOC 10-32	8	
15	10136	WASHER, FLAT, SAE 3/8	2	
16	10958	SWITCH, IGNITION VAN W/KEYS	1	
17	11078	KEY, IGNITION SWITCH	1	
18	11098	CIRCUIT BREAKER, 40A, 12V	1	
19	11534	NUT, "U" TYPE, 1/4-20	4	
20	11819	SCREW, HHC FLNGD 1/4-20 X 3/4	4	
21	12020	TERMINAL, WIRE	4	
22	12287	SCREW, THP 1/4-20 X 3/4-SS	4	
23	16723	NUT, HEX FINISH 8-32	2	
24	19301	TERMINAL STRIP, 10 POLE	.5	
25	21319	PANEL, CONTROL HHN 34VTD	1	
26	12018	RELAY, CONNECTOR.....	1	SAFETY ITEM
27	12017	RELAY, KILL .....	1	SAFETY ITEM
28	12014	WIRE, RELAY GROUND	1	
29	10019	NUT, NYLOC 10-32	1	
30	825572	IGNITION MODULE	1	

# HHN 34TVD — TOP RIGHT PANEL ASSY.

## TOP RIGHT PANEL ASSY.

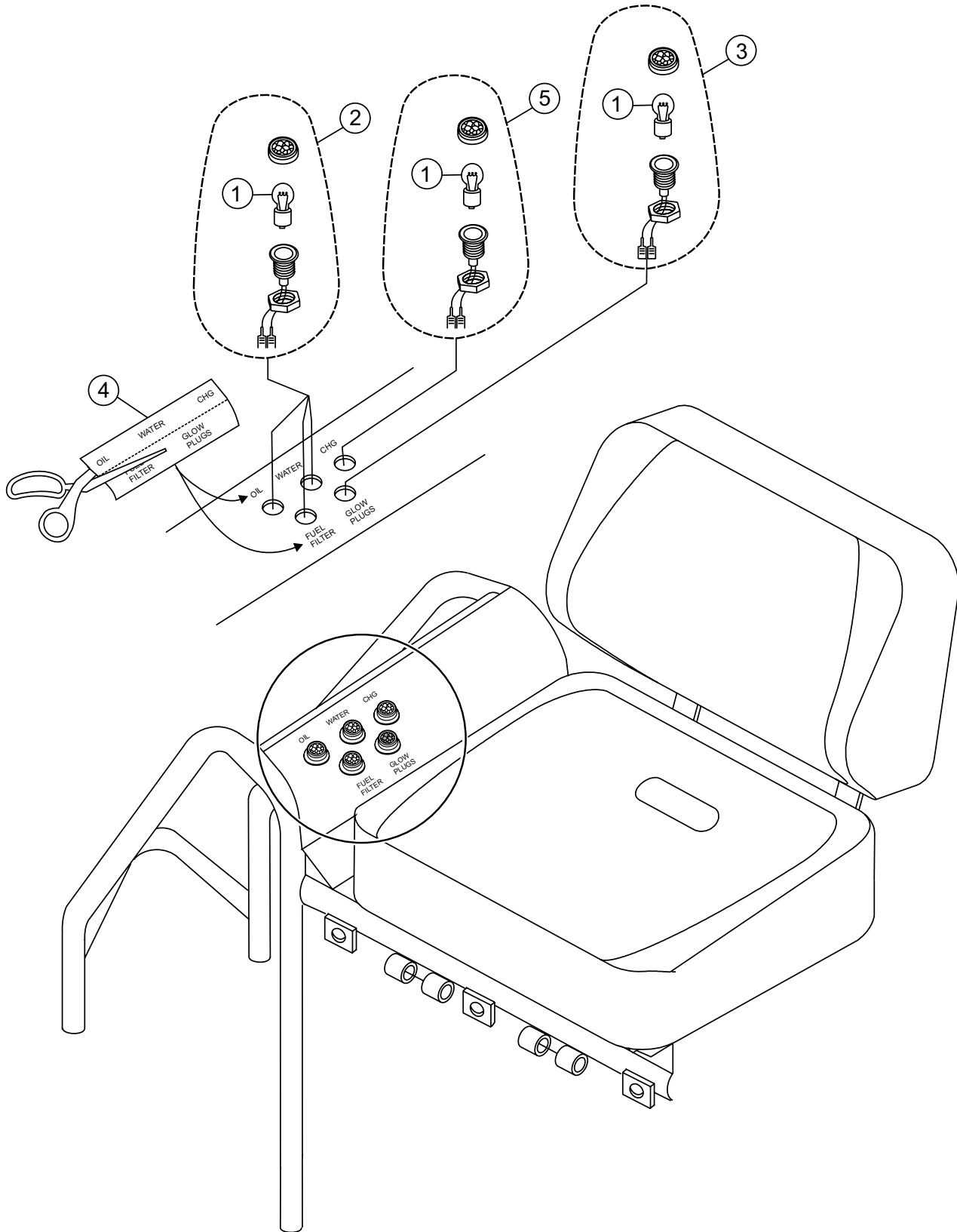

# HHN 34TVD — TOP RIGHT PANEL ASSY.

## TOP RIGHT PANEL ASSY.

<u>NO.</u>	<u>PART NO.</u>	<u>PART NAME</u>	<u>QTY.</u>	<u>REMARKS</u>
1	12307	BULB, INDICATOR LIGHT	5	
2	22212	PLUG, INDICATOR LIGHT RED .....	3.....	REPLACES P/N 12305
3	22213	PLUG, INDICATOR LIGHT YELLOW .....	1.....	REPLACES P/N 12306
4	12571	DECAL, INSTRUMENT LIGHT 5 PANEL	1	
5	22270	PLUG, INDICATOR LIGHT RED, CHARGE	1	

# HHN 34TVD — E-Z MOVER AND LIFT HANDLE ASSY.

E-Z MOVER (EMR2) AND LIFT HANDLE ASSY.

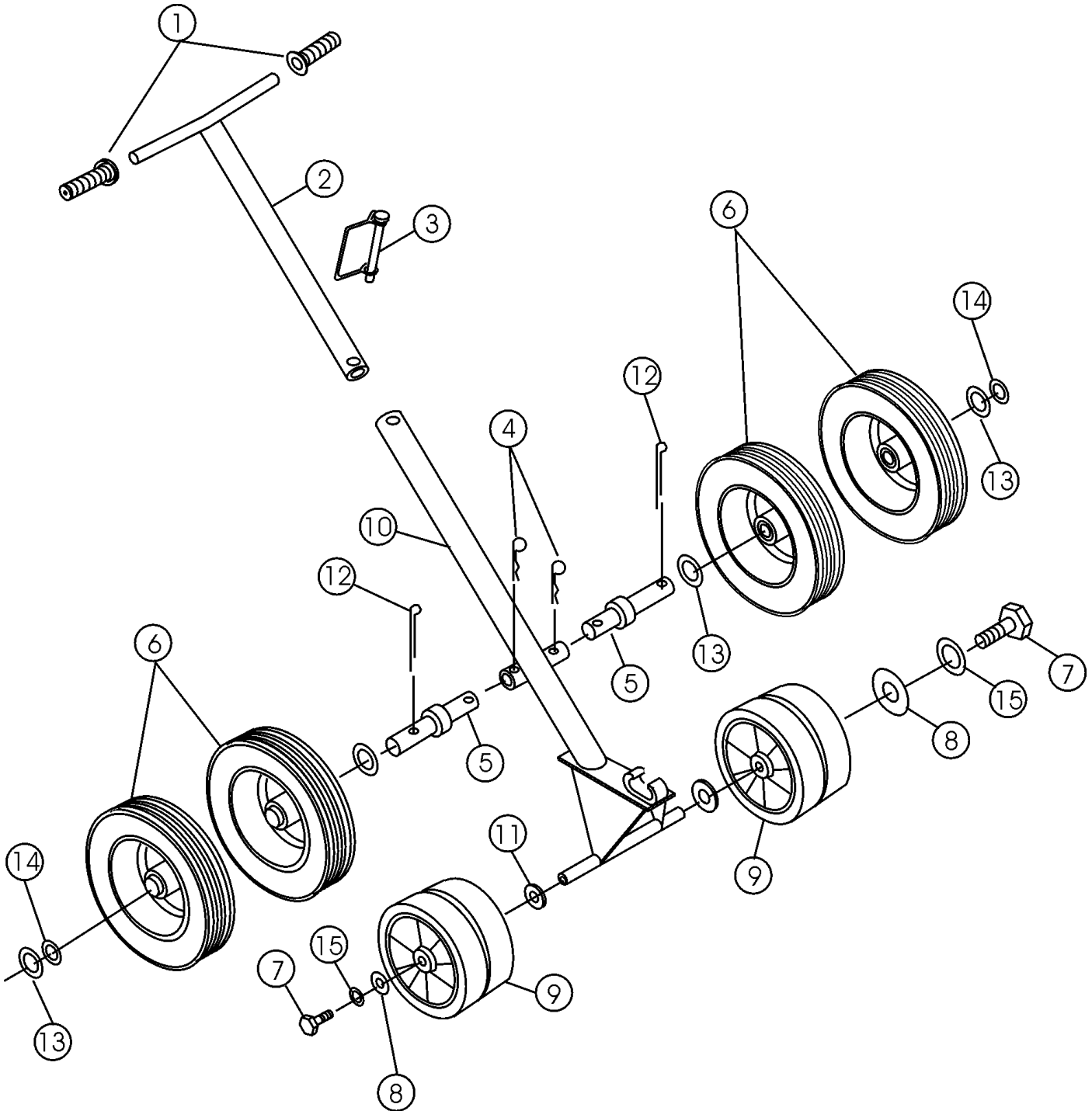

## HHN 34TVD — E-Z MOVER AND LIFT HANDLE ASSY.

E-Z MOVER (EMR2) AND LIFT HANDLE ASSY.

<u>NO.</u>	<u>PART NO.</u>	<u>PART NAME</u>	<u>QTY.</u>	<u>REMARKS</u>
1	0189	HAND GRIP	2	
2	2336	UPPER HANDLE	1	
3	1869	SNAP PIN	1	
4	7170	CLIP	2	
5	11684	DOLLY AXLE	2	
6	10440	WHEEL & TIRE	4	
7	0655	SCREW, HHCS 5/16-18 x 3/4"	2	
8	0300 B	FLAT WASHER 5/16"	2	
9	2364	WHEEL	2	
10	10445	FRAME	1	
11	4684	FLAT WASHER 5/8"	2	
12	0183	COTTER PIN	2	
13	10446	FLAT WASHER 3/4"	8	
14	8151	FLAT WASHER 3/4" SAE	8	
15	0161 C	LOCK WASHER 5/16"	2	

EMR-2 E-Z MOVER ASSY. — PURCHASE THROUGH MQ UNIT SALES DEPT.

# TERMS AND CONDITIONS OF SALE — PARTS

## PAYMENT TERMS

Terms of payment for parts are net 30 days.

## FREIGHT POLICY

All parts orders will be shipped collect or prepaid with the charges added to the invoice. All shipments are F.O.B. point of origin. Multiquip's responsibility ceases when a signed manifest has been obtained from the carrier, and any claim for shortage or damage must be settled between the consignee and the carrier.

## MINIMUM ORDER

The minimum charge for orders from Multiquip is \$15.00 net. Customers will be asked for instructions regarding handling of orders not meeting this requirement.

## RETURNED GOODS POLICY

Return shipments will be accepted and credit will be allowed, subject to the following provisions:

1. A Returned Material Authorization must be approved by Multiquip prior to shipment.
2. To obtain a Return Material Authorization, a list must be provided to Multiquip Parts Sales that defines item numbers, quantities, and descriptions of the items to be returned.
  - a. The parts numbers and descriptions must match the current parts price list.
  - b. The list must be typed or computer generated.
  - c. The list must state the reason(s) for the return.
  - d. The list must reference the sales order(s) or invoice(s) under which the items were originally purchased.
  - e. The list must include the name and phone number of the person requesting the RMA.
3. A copy of the Return Material Authorization must accompany the return shipment.
4. Freight is at the sender's expense. All parts must be returned freight prepaid to Multiquip's designated receiving point.

5. Parts must be in new and resalable condition, in the original Multiquip package (if any), and with Multiquip part numbers clearly marked.
6. The following items are not returnable:
  - a. Obsolete parts. (If an item is in the price book and shows as being replaced by another item, it is obsolete.)
  - b. Any parts with a limited shelf life (such as gaskets, seals, "O" rings, and other rubber parts) that were purchased more than six months prior to the return date.
  - c. Any line item with an extended dealer net price of less than \$5.00.
  - d. Special order items.
  - e. Electrical components.
  - f. Paint, chemicals, and lubricants.
  - g. Decals and paper products.
  - h. Items purchased in kits.
7. The sender will be notified of any material received that is not acceptable.
8. Such material will be held for five working days from notification, pending instructions. If a reply is not received within five days, the material will be returned to the sender at his expense.
9. Credit on returned parts will be issued at dealer net price at time of the original purchase, less a 15% restocking charge.
10. In cases where an item is accepted, for which the original purchase document can not be determined, the price will be based on the list price that was effective twelve months prior to the RMA date.
11. Credit issued will be applied to future purchases only.

## PRICING AND REBATES

Prices are subject to change without prior notice. Price changes are effective on a specific date and all orders received on or after that date will be billed at the revised price. Rebates for price declines and added charges for price increases will not be made for stock on hand at the time of any price change.

Multiquip reserves the right to quote and sell direct to Government agencies, and to Original Equipment Manufacturer accounts who use our products as integral parts of their own products.

## SPECIAL EXPEDITING SERVICE

A \$35.00 surcharge will be added to the invoice for special handling including bus shipments, insured parcel post or in cases where Multiquip must personally deliver the parts to the carrier.

## LIMITATIONS OF SELLER'S LIABILITY

Multiquip shall not be liable hereunder for damages in excess of the purchase price of the item with respect to which damages are claimed, and in no event shall Multiquip be liable for loss of profit or good will or for any other special, consequential or incidental damages.

## LIMITATION OF WARRANTIES

No warranties, express or implied, are made in connection with the sale of parts or trade accessories nor as to any engine not manufactured by Multiquip. Such warranties made in connection with the sale of new, complete units are made exclusively by a statement of warranty packaged with such units, and Multiquip neither assumes nor authorizes any person to assume for it any other obligation or liability whatever in connection with the sale of its products. Apart from such written statement of warranty, there are no warranties, express, implied or statutory, which extend beyond the description of the products on the face hereof.

Effective: February 22, 2006



# PARTS MANUAL

## HERE'S HOW TO GET HELP

PLEASE HAVE THE MODEL AND SERIAL  
NUMBER ON-HAND WHEN CALLING

### UNITED STATES

#### *Multiquip Corporate Office*

18910 Wilmington Ave.  
Carson, CA 90746  
Contact: mq@multiquip.com

Tel. (800) 421-1244  
Fax (800) 537-3927

#### *Service Department*

800-421-1244  
310-537-3700

Fax: 310-537-4259

#### *Technical Assistance*

800-478-1244

Fax: 310-943-2238

#### *MQ Parts Department*

800-427-1244  
310-537-3700

Fax: 800-672-7877  
Fax: 310-637-3284

#### *Warranty Department*

800-421-1244  
310-537-3700

Fax: 310-943-2249

---

### MEXICO

#### *MQ Cipsa*

Carr. Fed. Mexico-Puebla KM 126.5  
Momoxpan, Cholula, Puebla 72760 Mexico  
Contact: pmastretta@cipsa.com.mx

Tel: (52) 222-225-9900  
Fax: (52) 222-285-0420

### CANADA

#### *Multiquip*

4110 Industriel Boul.  
Laval, Quebec, Canada H7L 6V3  
Contact: jmartin@multiquip.com

Tel: (450) 625-2244  
Tel: (877) 963-4411  
Fax: (450) 625-8664

---

### UNITED KINGDOM

#### *Multiquip (UK) Limited Head Office*

Unit 2, Northpoint Industrial Estate,  
Globe Lane,  
Dukinfield, Cheshire SK16 4UJ  
Contact: sales@multiquip.co.uk

Tel: 0161 339 2223  
Fax: 0161 339 3226

© COPYRIGHT 2011, MULTIQUIP INC.

Multiquip Inc, the MQ logo and the Whiteman logo are registered trademarks of Multiquip Inc. and may not be used, reproduced, or altered without written permission. All other trademarks are the property of their respective owners and used with permission.

This manual MUST accompany the equipment at all times. This manual is considered a permanent part of the equipment and should remain with the unit if resold.

The information and specifications included in this publication were in effect at the time of approval for printing. Illustrations, descriptions, references and technical data contained in this manual are for guidance only and may not be considered as binding. Multiquip Inc. reserves the right to discontinue or change specifications, design or the information published in this publication at any time without notice and without incurring any obligations.

Your Local Dealer is:

